

Introduction

When designing a motor control circuit, it is vital to determine how to deliver the high current required to drive the motor. Designers must choose whether to use monolithic integrated circuits that have internal power devices, or gate driver ICs and discrete external power MOSFETs. This article discusses the advantages and disadvantages of each approach and provides guidance on when to choose either solution.

Monolithic Solutions

The first option is to use a monolithic driver IC to drive a motor. An integrated IC is comprised of one silicon die in a package — this die integrates logic, support, and protection circuitry, as well as the power devices (e.g. power MOSFETs) that drive the current through the motor.

Because the MOSFETs in a monolithic solution are fabricated on the same die as the control circuitry, these solutions provide the benefit of accurate current measurement. Monolithic ICs also provide robust protection features, such as over-current protection (OCP) and over-temperature protection (OTP), since this circuits can be placed in close proximity to the MOSFETs on the silicon.

Integrated drivers are limited to voltage and current ratings that are compatible with IC processes, which means that the highest available voltage rating is between 80V and 100V. In addition, these drivers can drive up to about 15A.

Monolithic drivers are used almost exclusively in high-volume applications such as printers, where supply voltages are typically below 35V and motor currents are below 5A.

An example of an integrated driver is the [MPQ6541](#) from Monolithic Power Systems. The MPQ6541 is an automotive-specified, 3-channel power stage. It is rated at a supply voltage of up to 45V and a continuous load current of 8A, or a peak current of 15A per channel. This motor drive integrates six MOSFETs that have an $R_{DS(ON)}$ of 15m Ω each. It is the smallest device available at this power level, packaged in a TQFN-26 (6mmx5mm) flip-chip package.

Figure 1 shows the MPQ6541's block diagram.

Note that the MPQ6541 integrates current measurement for each channel. This eliminates the need for large and expensive current-sensing resistors or current-sense amplifiers.

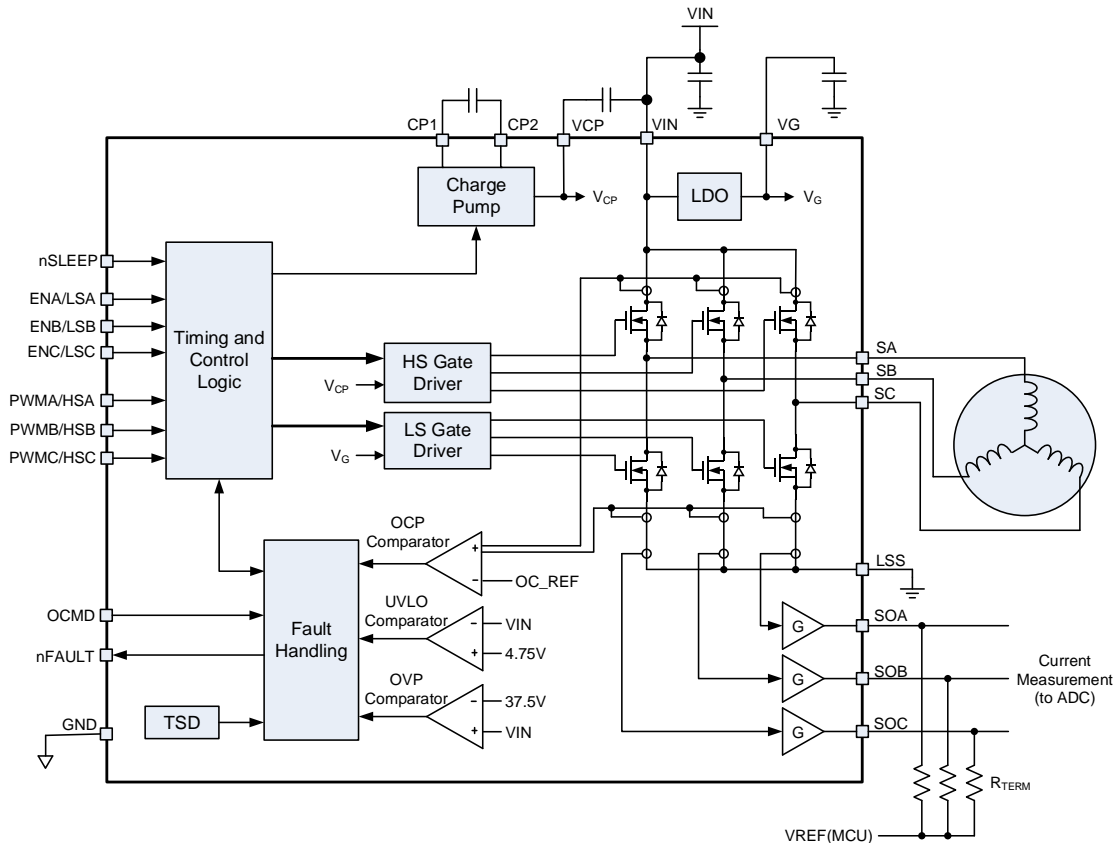

Figure 1: MPQ6541 Block Diagram

Gate Drivers (Pre-Drivers)

The second option uses discrete power MOSFETs (or in some cases, other power devices) to drive the current through the motor, and the MOSFETs are controlled via a gate driver IC, pre-driver, or multiple gate drivers.

Monolithic solutions do not exist for applications that require high voltages exceeding 100V or very high currents. In these cases, a gate driver, plus discrete MOSFETs, is required.

Since multiple devices are required in this scenario (sometimes as many as three gate drivers and six power MOSFETs), the solution size — that is, the PCB area occupied by the motor driver — is much larger than that which is required by a monolithic driver.

An example of a highly integrated gate driver is the [MPQ6533](#), a 3-channel gate driver IC with integrated features like slew rate control and internal diagnostic functions. This device is available in a QFN-32 (5mmx5mm) package, which is only slightly smaller than the monolithic MPQ6541.

Figure 2 shows the MPQ6533's block diagram. Note that this solution requires six power MOSFETs. Generally, three dual MOSFETs (two MOSFETs packaged together into one IC package) are used.

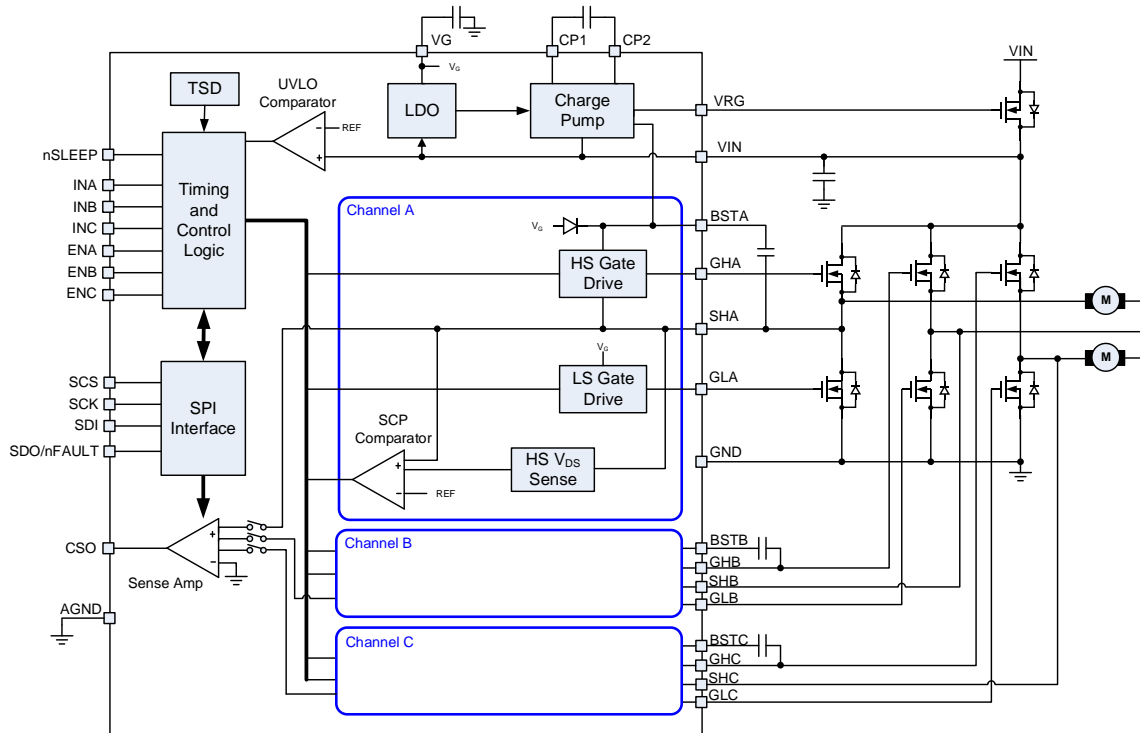

Figure 2: MPQ6533 Block Diagram

Cost Considerations

Analog and mixed signal IC processes are much more complex than dedicated discrete MOSFET processes. Since fabricating low $R_{DS(ON)}$ MOSFETs in an IC process takes a large area of silicon, the cost of a device with the same $R_{DS(ON)}$ and voltage in a MOSFET process is usually higher than it would be to fabricate a similar device in a dedicated discrete MOSFET process.

For lower-current and/or lower-voltage motor drivers, the penalty for fabricating the MOSFETs in the IC process is small. Since the control and protection functions take up a big part of the die, the added area for the MOSFETs does not increase the cost as much as using external MOSFETs.

For high-current applications, however, the cost of the MOSFETs in an IC process starts to dominate the cost of the device. Even though there are monolithic motor drivers that can support a 15A motor current, they typically are more expensive than an implementation using a gate driver plus discrete MOSFETs.

There are cases where the small size of a monolithic part is valued so highly that it justifies a more expensive solution. For example, some systems require an integrated driver inside a motor, where there is little space available. In these scenarios, a solution using a gate driver plus MOSFETs simply may not fit in the constrained space.

To get a rough idea of the relative cost of monolithic solutions vs. a gate driver solution, we can compare the cost of a monolithic IC plus a gate driver IC with three dual MOSFETs and three current-sense resistors. Other supporting components, such as bypass capacitors, have similar prices between both solutions. Note that these costs are based on low quantity catalog prices; actual volume production prices are typically much lower.

Table 1 shows the cost comparison between a dedicated monolithic IC and gate driver IC with discrete MOSFETs.

Table 1: Cost Comparison

	Monolithic IC	Gate Driver IC
Component cost	IC: \$6.00	IC: \$2.05
		Dual MOSFETs (x3): \$1.80
		Current-sense resistors: \$0.39
Total cost	\$6.00	\$4.24

Solution Size

Monolithic drivers are almost always smaller than the equivalent solution using gate drivers and discrete MOSFETs.

As an example, we can compare the PCB area occupied by the MPQ6541 to the MPQ6533 with additional power MOSFETs (see Figure 3). Although both parts are industry leaders in terms of small package size, they significantly differ in size, with the MPQ6541 occupying 130mm² and the MPQ6533 occupying 520mm², which is four times larger. Note that the gate driver solution shown here uses dual MOSFETs in small packages; in other cases, the MOSFETs can be much larger, which further increases the solution’s PCB area.

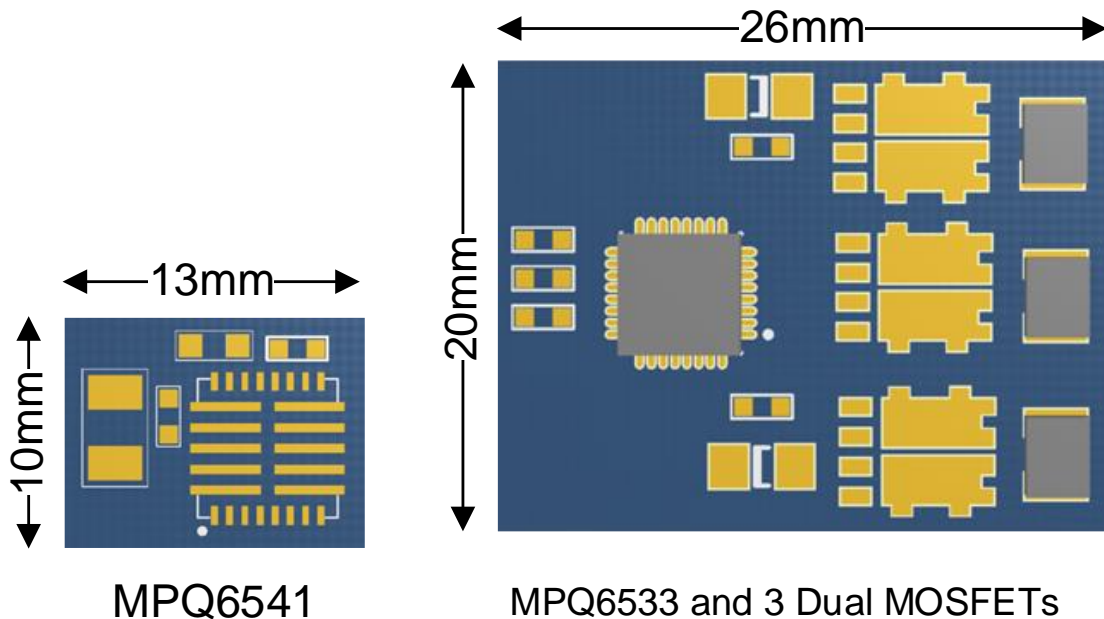

Figure 3: MPQ6541 vs. MPQ6533 Solution Size

Thermal Considerations

To effectively dissipate the heat that is generated in the power MOSFETs, the PCB is typically used as a heatsink. Larger packages typically have better thermal conductivity to the PCB, which means that bigger solutions are better from a thermal dissipation standpoint. This can work in favor of solutions that use gate drivers, since the power MOSFETs are typically large. Low $R_{DS(ON)}$ power MOSFETs are readily available, so in some cases — especially with applications that need to operate in harsh environments — thermal considerations may preclude the use of a monolithic driver.

Monolithic drivers come in smaller packages. To compensate for the higher thermal resistance in these packages, the $R_{DS(ON)}$ for a given current must be lower than it would be for a comparable solution using a discrete MOSFET.

Consider the MPQ6541 and its small size. If the PCB is designed correctly, a significant current can be driven by this part. Figure 4 shows the MPQ6541’s temperature on a 5cmx5cm, 2-layer PCB, while delivering 6A of current to a 3-phase brushless motor. The case temperature measured was 38°C above the ambient temperature. A 4-layer PCB with internal planes would further lower the temperature rise.

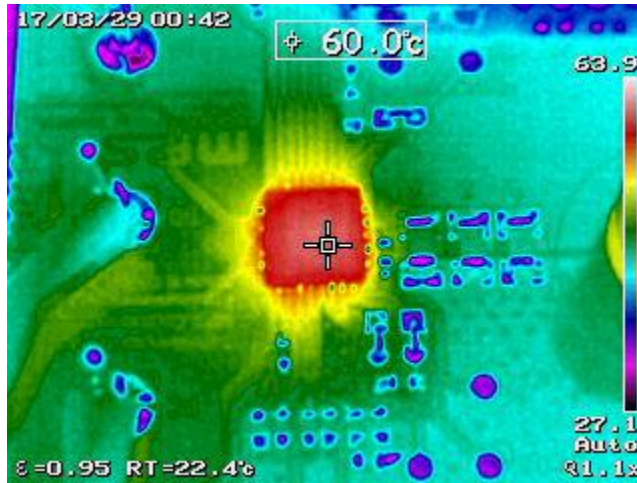

Figure 4: MPQ6541 Thermal Image

Table 2 summarizes the main differences between integrated and gate driver solutions.

Table 2: Part Comparison

	Monolithic Device	Pre-Driver (Plus MOSFETs)
PCB Area	Smaller solution	Larger solution
Maximum Practical Voltage and Current	About 100V, 15A	Unlimited
Cost	<ul style="list-style-type: none"> Low current: Low cost High current: Higher cost 	<ul style="list-style-type: none"> Low current: Higher cost High current: Lower cost
Current Measurement	Accurate internal measurement	Requires external shunts and amplifiers
Protection Features	Accurate temperature and over-current protection (OCP)	Requires external components, temperature measurement not as accurate
Thermal Capability	Small packages have higher thermal resistance	Large MOSFETs can spread heat better

Conclusion

The choice between monolithic motor drivers and a gate driver with external MOSFET solutions to drive motors is complex. Tradeoffs between cost, solution size, and thermal characteristics must be considered.

For very small motors, monolithic drivers are the best solution. Likewise, for very high-power motors, a solution using gate drivers and discrete MOSFETs should be used. However, there is a large overlap between both solutions, so designers should consider the specifications of their application when making their choice. For more information, see MPS [motor driver solutions](#).