

Title: EVINAG-01-A		
Size: A4	Revision: 0.2	
Date: 3/16/2023	Sheet: 1 of 13	
Engineer: Yuxin Zhang		

1

2

3

4

PMBus Connector

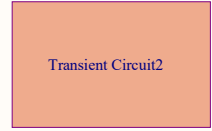
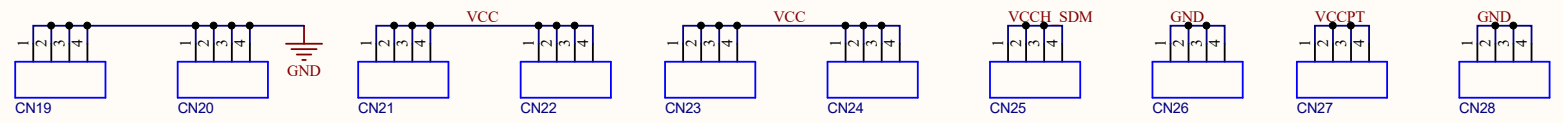
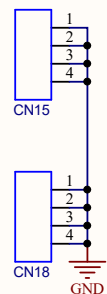
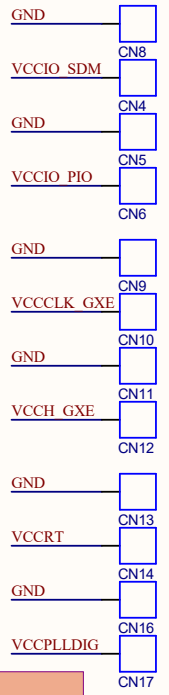
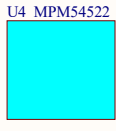
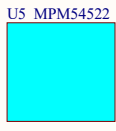
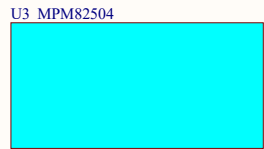
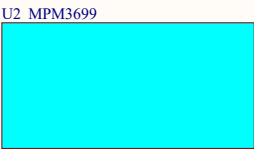
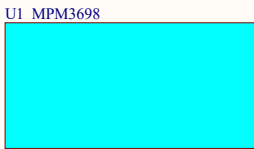
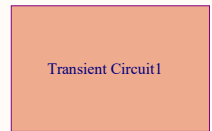
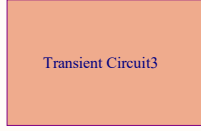
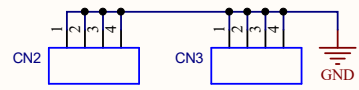
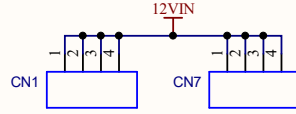
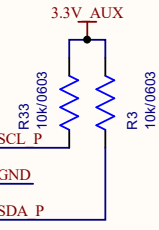
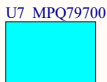
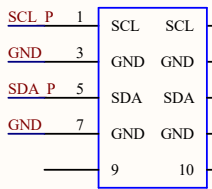

Title:	EVINAG-01-A	
Size:	A4	Revision: 0.2
Date:	3/16/2023	Sheet: 2 of 13
Engineer:	Yuxin Zhang	

1

2

3

4

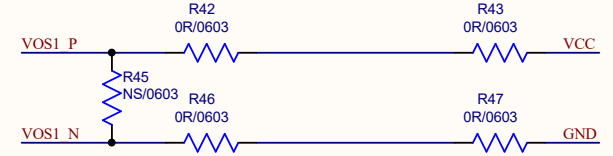
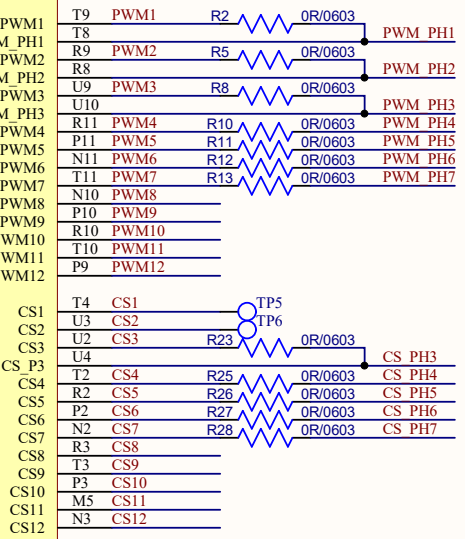
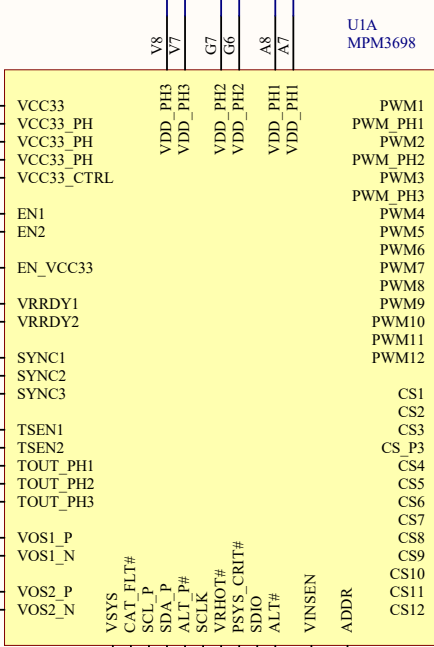
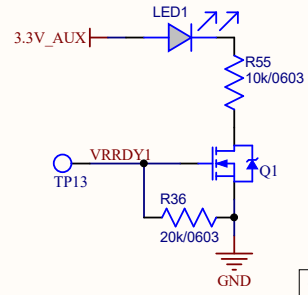
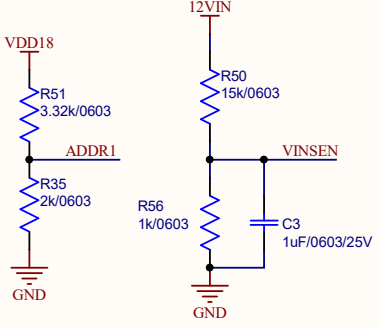
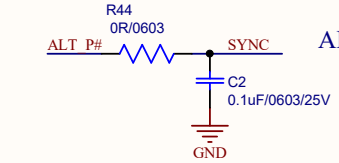
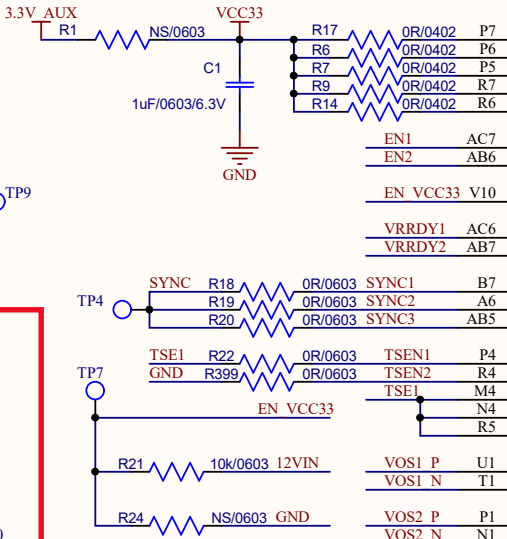
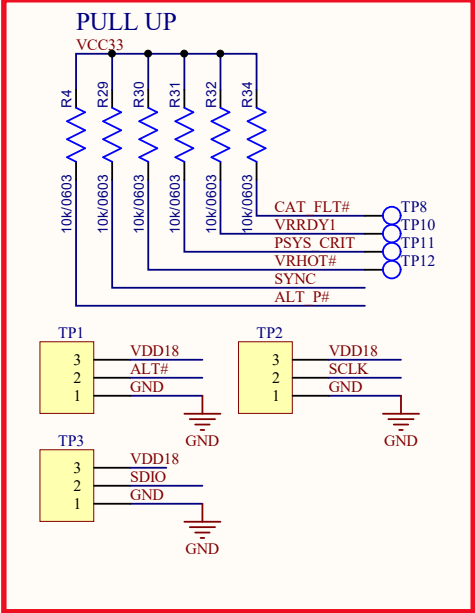
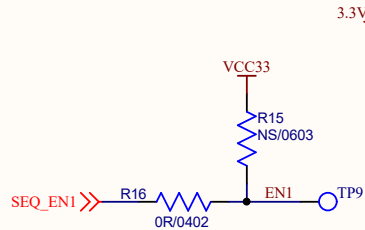

Title: EVINAG-01-A	
Size: A4	Revision: 0.2
Date: 3/16/2023	Sheet: 3 of 13
Engineer: Yuxin Zhang	

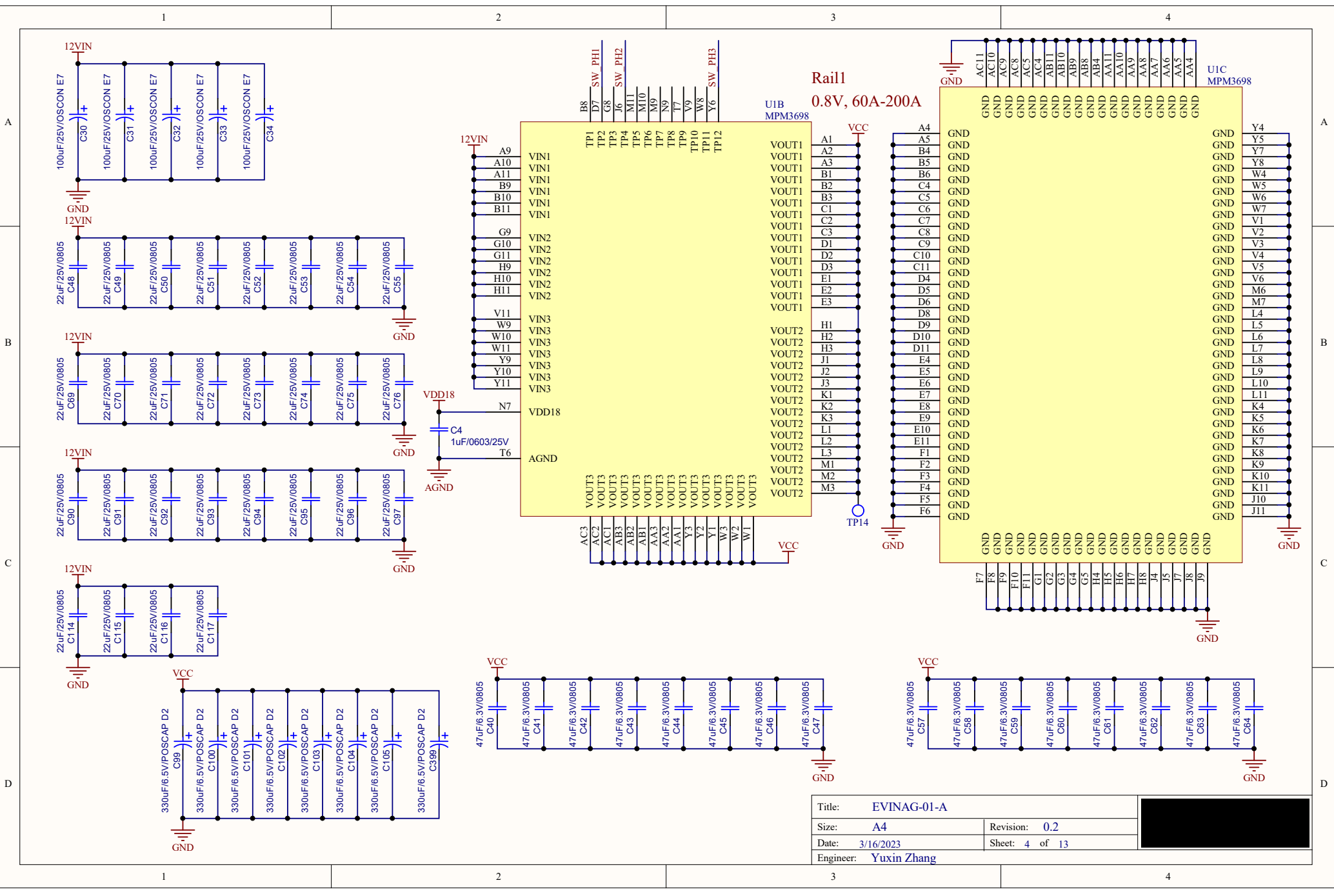

Title:	EVINAG-01-A	
Size:	A4	Revision: 0.2
Date:	3/16/2023	Sheet: 4 of 13
Engineer:	Yuxin Zhang	



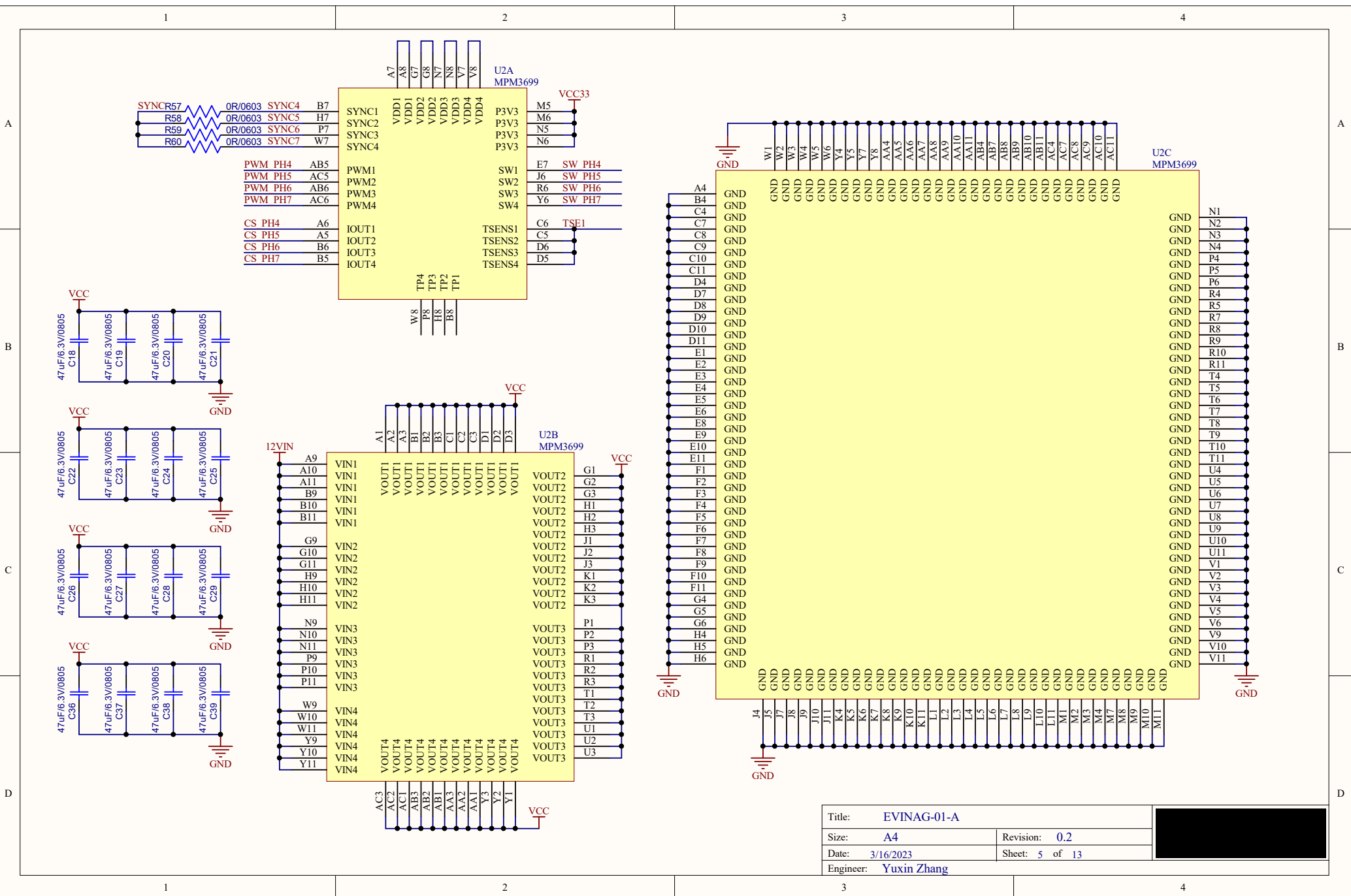

Title: EVINAG-01-A		
Size: A4	Revision: 0.2	
Date: 3/16/2023	Sheet: 5 of 13	
Engineer: Yuxin Zhang		

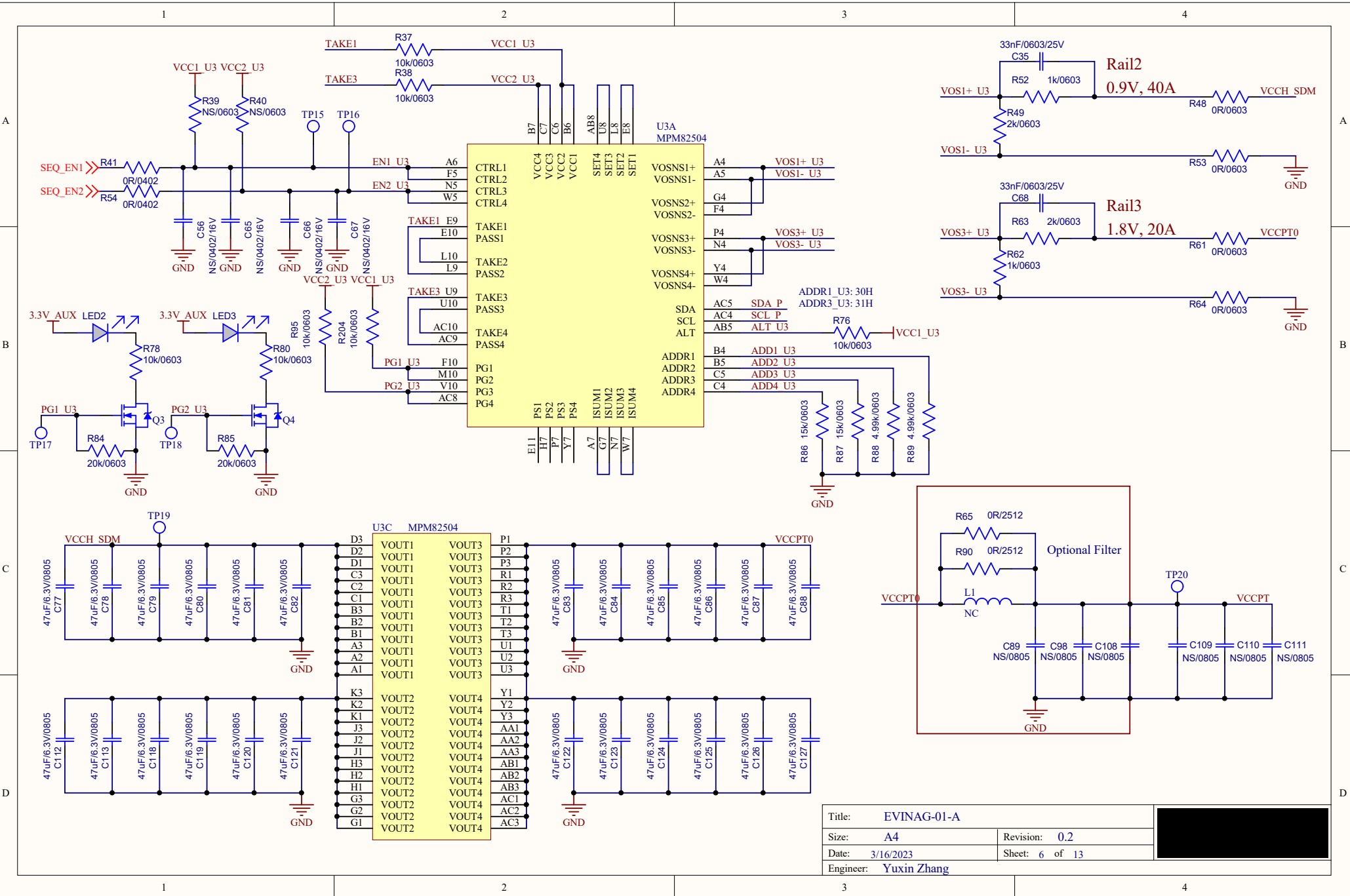

Title:	EVINAG-01-A	
Size:	A4	Revision: 0.2
Date:	3/16/2023	Sheet: 6 of 13
Engineer:	Yuxin Zhang	



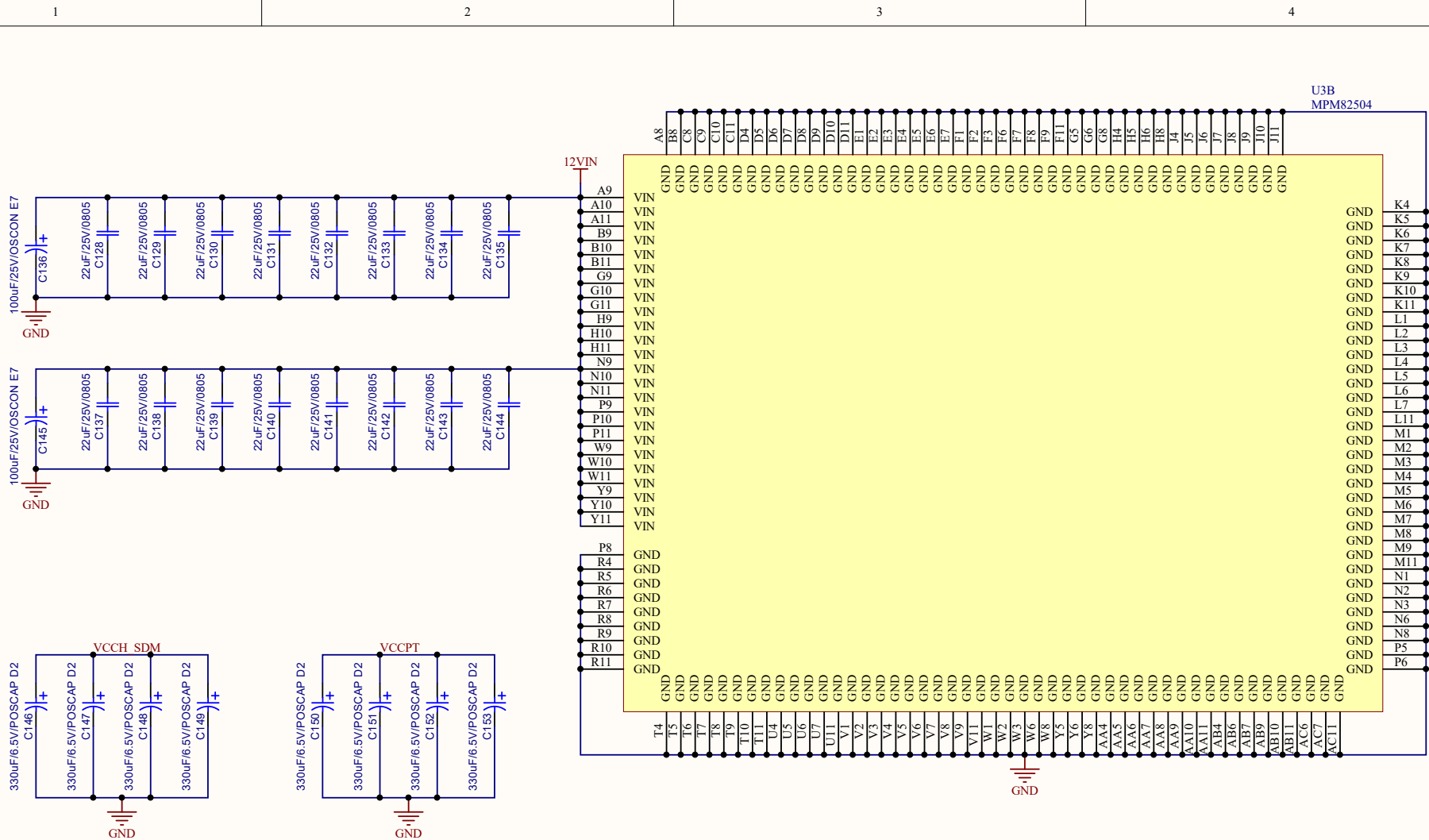

Title: EVINAG-01-A	
Size: A4	Revision: 0.2
Date: 3/16/2023	Sheet: 7 of 13
Engineer: Yuxin Zhang	



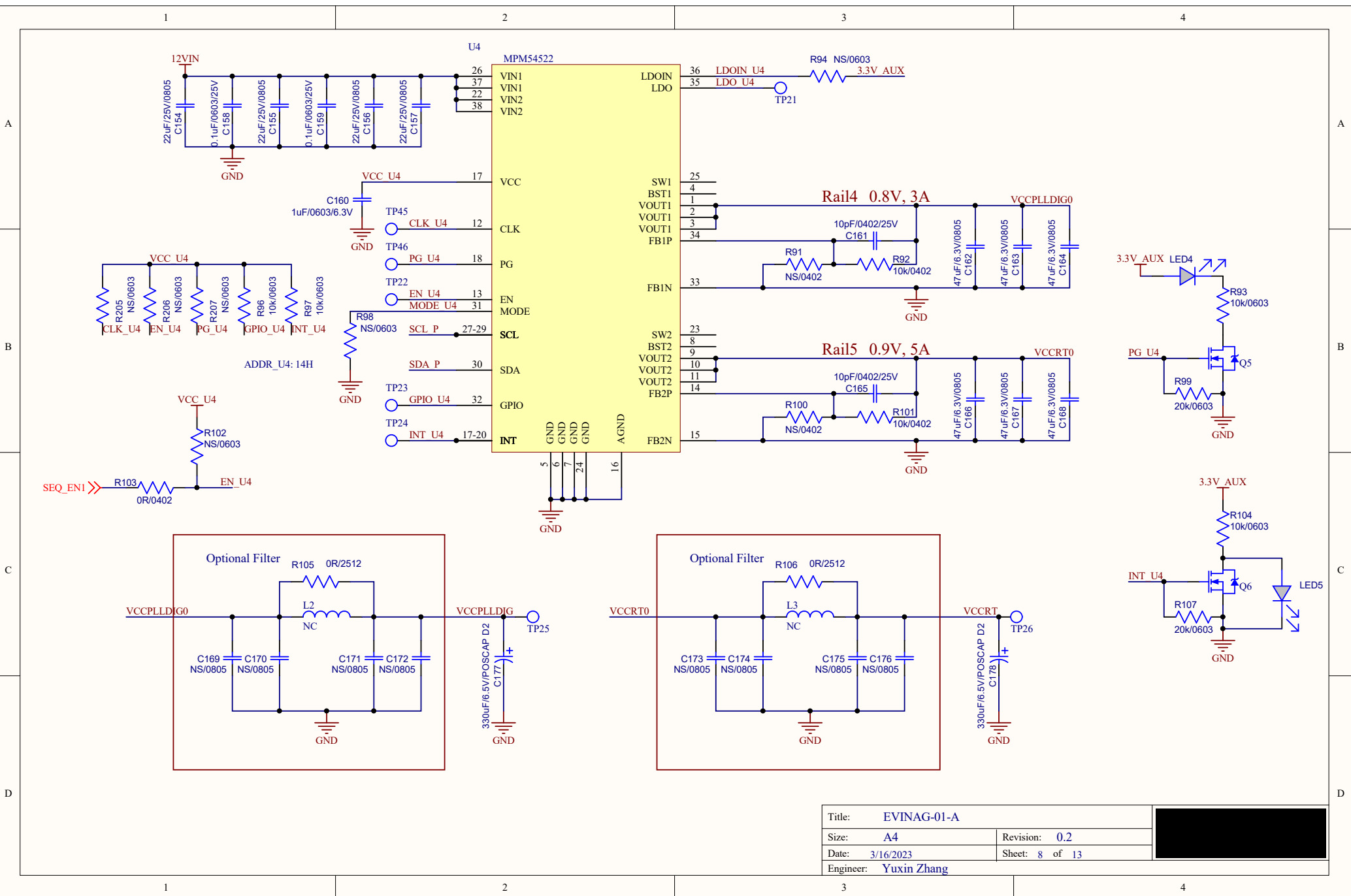

Title:	EVINAG-01-A	
Size:	A4	Revision: 0.2
Date:	3/16/2023	Sheet: 8 of 13
Engineer:	Yuxin Zhang	

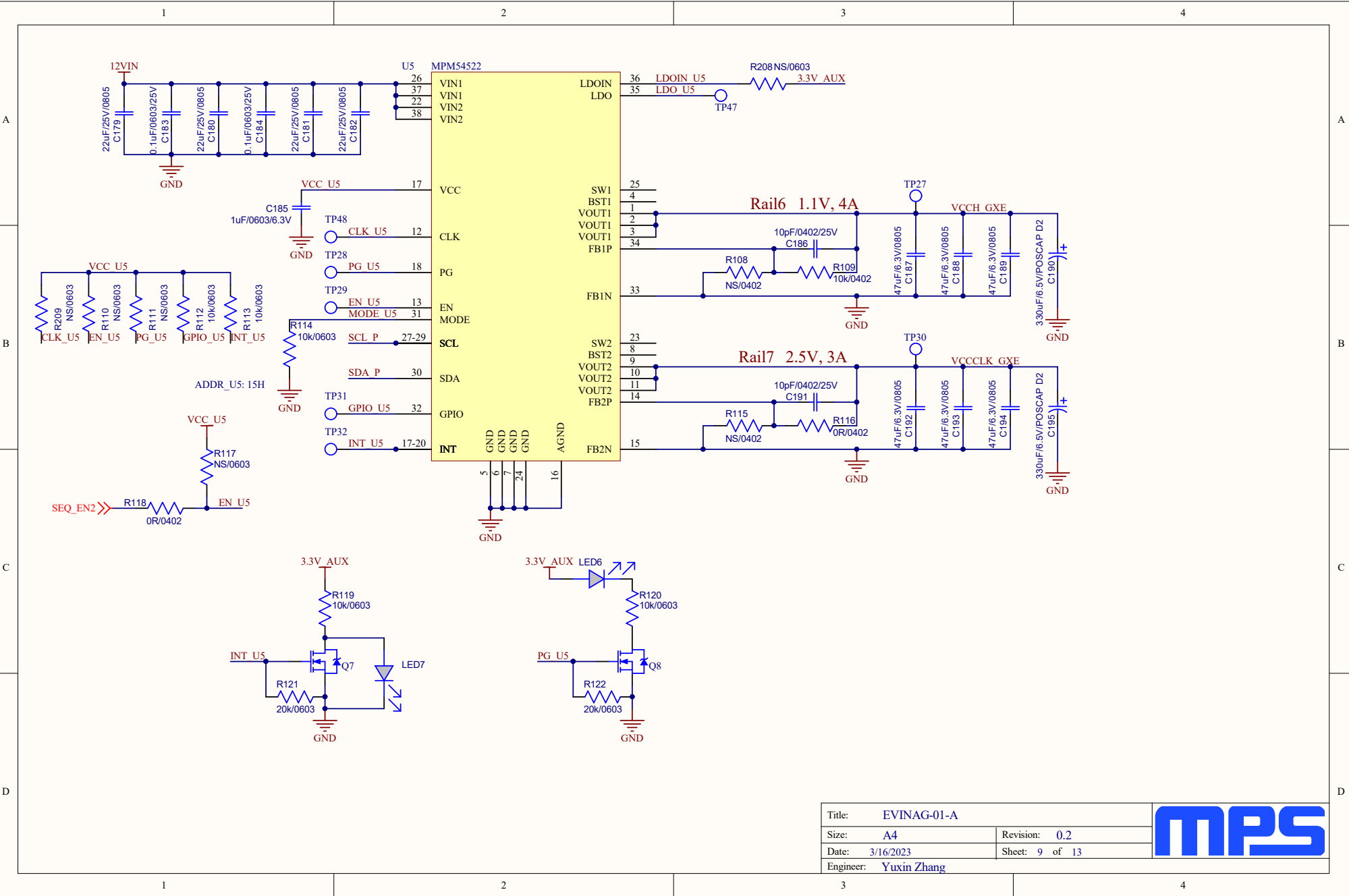

Title: EVINAG-01-A	
Size: A4	Revision: 0.2
Date: 3/16/2023	Sheet: 9 of 13
Engineer: Yuxin Zhang	



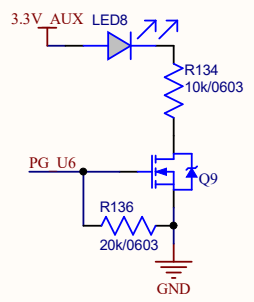
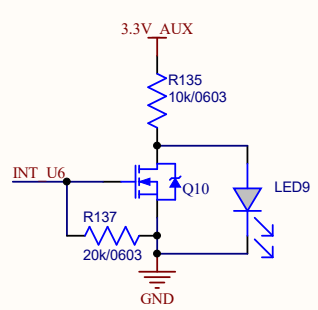
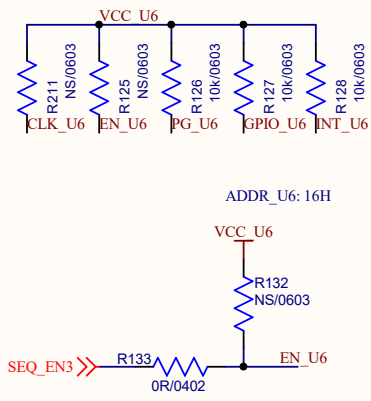
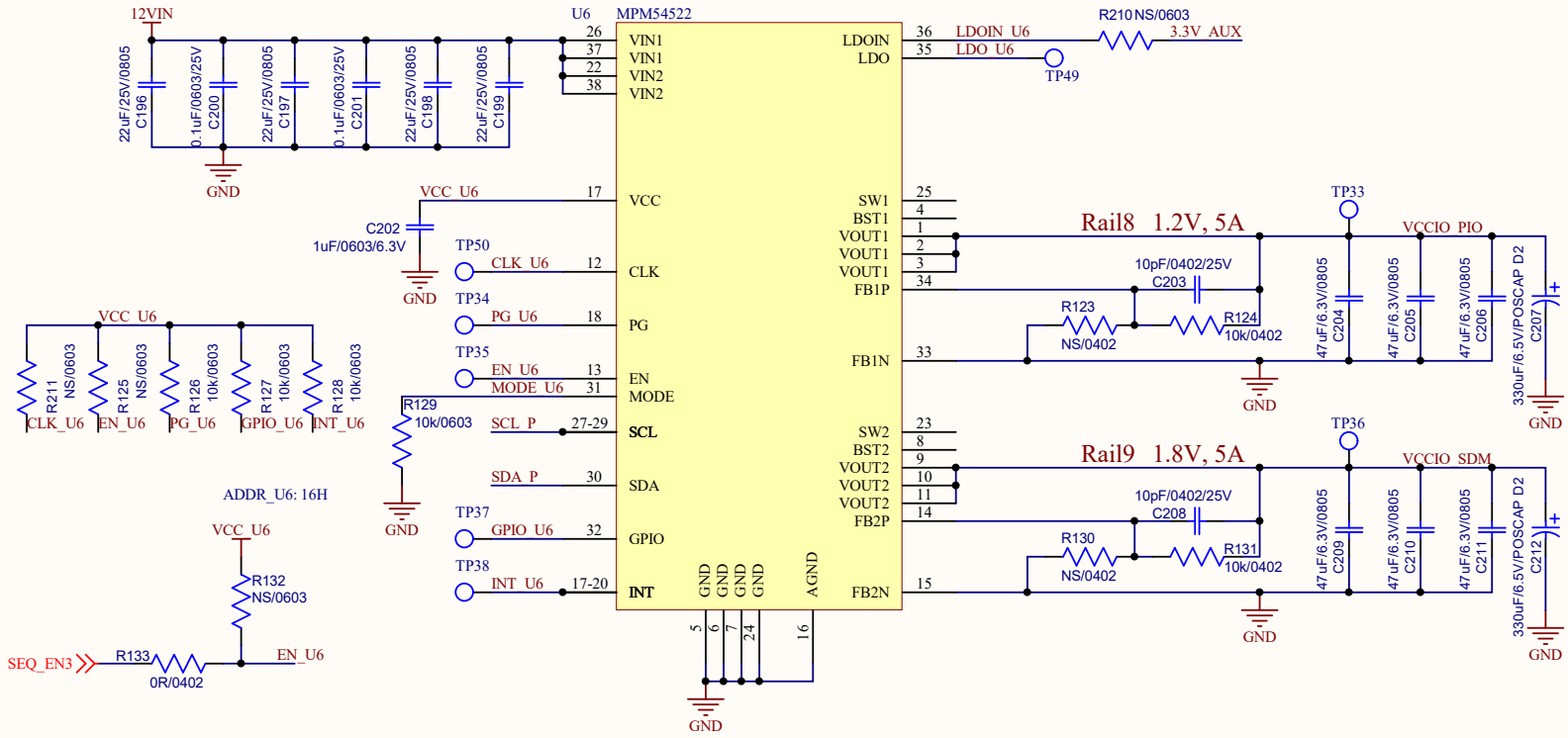

Title: EVINAG-01-A		
Size: A4	Revision: 0.2	
Date: 3/16/2023	Sheet: 10 of 13	
Engineer: Yuxin Zhang		

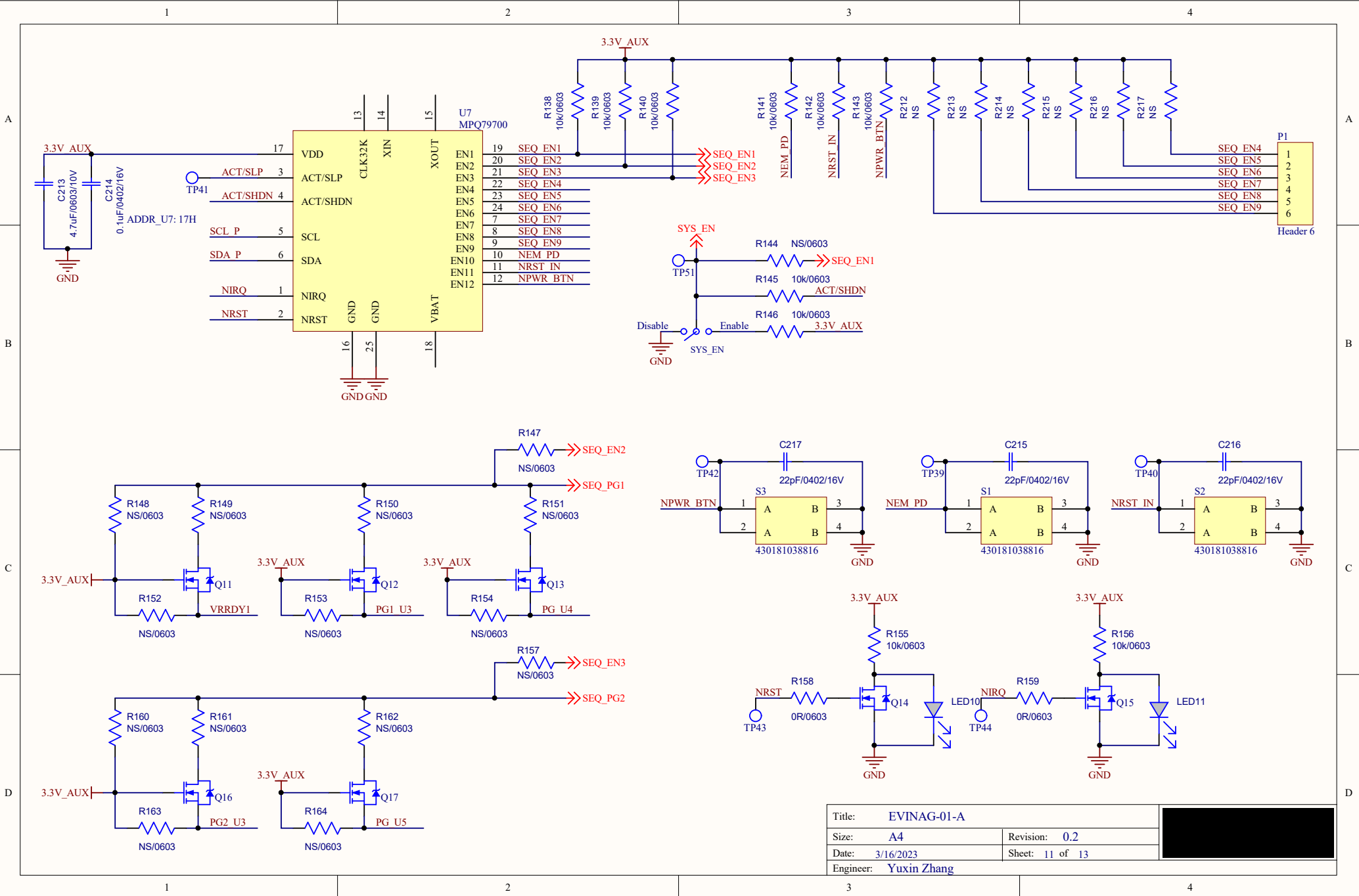

Title:	EVINAG-01-A	
Size:	A4	Revision: 0.2
Date:	3/16/2023	Sheet: 11 of 13
Engineer:	Yuxin Zhang	



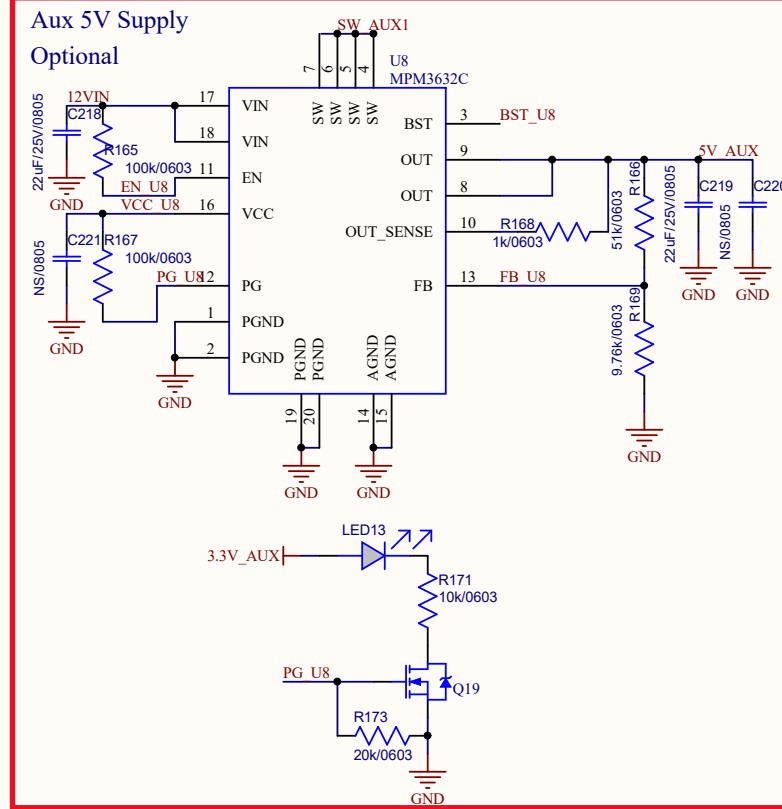
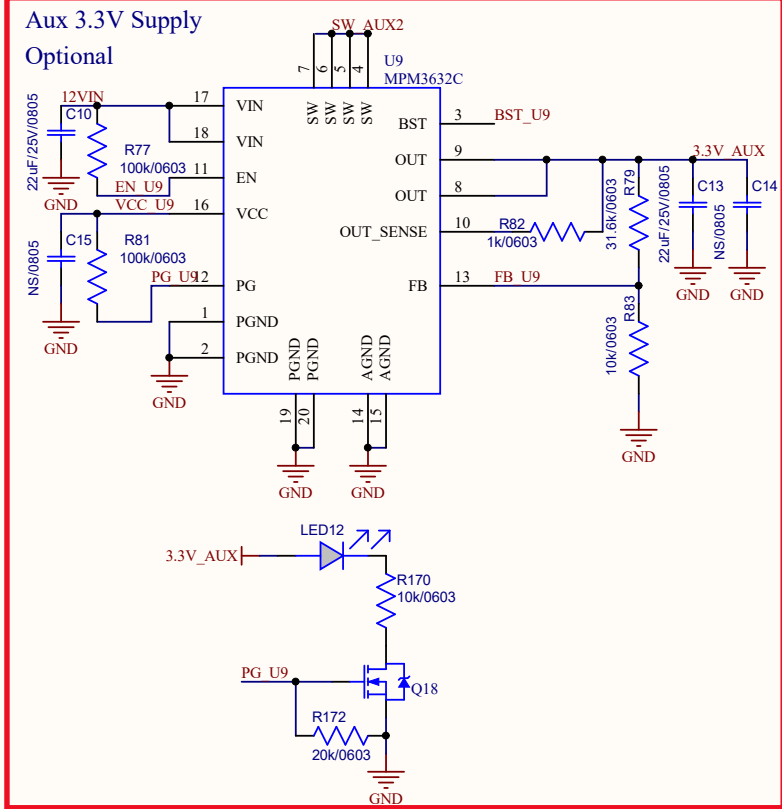

Title:	EVINAG-01-A	
Size:	A4	Revision: 0.2
Date:	3/16/2023	Sheet: 12 of 13
Engineer:	Yuxin Zhang	

