

Introduction

X-ray imaging is used for a wide range of applications — from medical diagnostics to security screening to food inspection, they can identify materials, flaws, and quantity counts as needed. Regardless of how they are being used, it is vital for x-rays to provide accurate and high-quality imaging.

The [MDC91128](#) is a highly integrated, low-noise, current input [analog-to-digital converter \(ADC\)](#) designed to scan 2D x-ray, 3D computed tomography (CT), and other photodiode applications with a high channel count. Figure 1 shows an actual x-ray scan from a system using the MDC91128.

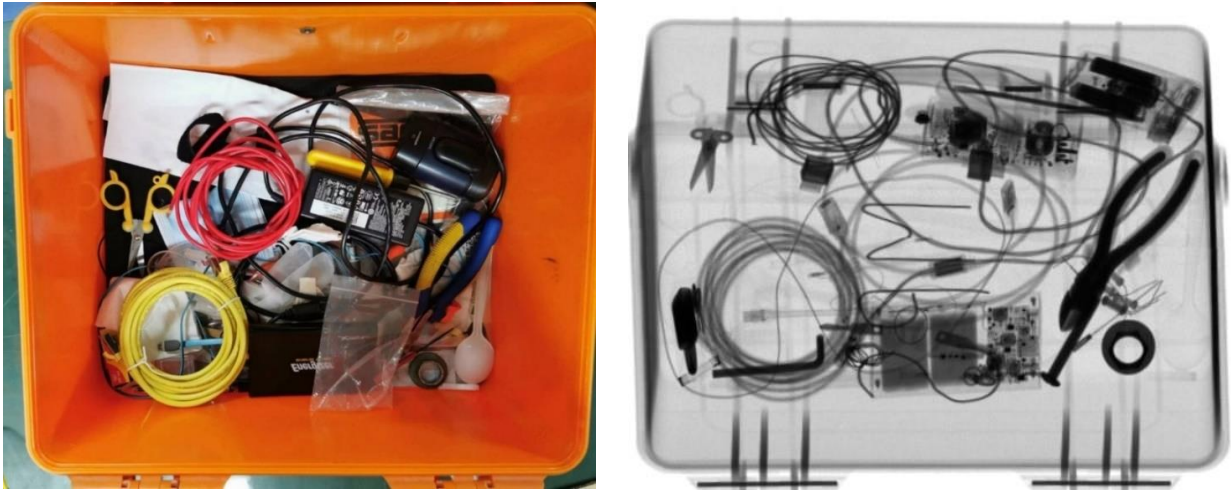

Figure 1: X-Ray Image Captured Using the MDC91128

Scanning X-Ray Systems

In a typical scanning x-ray application used for baggage scanners and other security and quality inspections, a source generates x-rays that are directed at a target passing below the x-ray on a conveyor belt (see Figure 2).

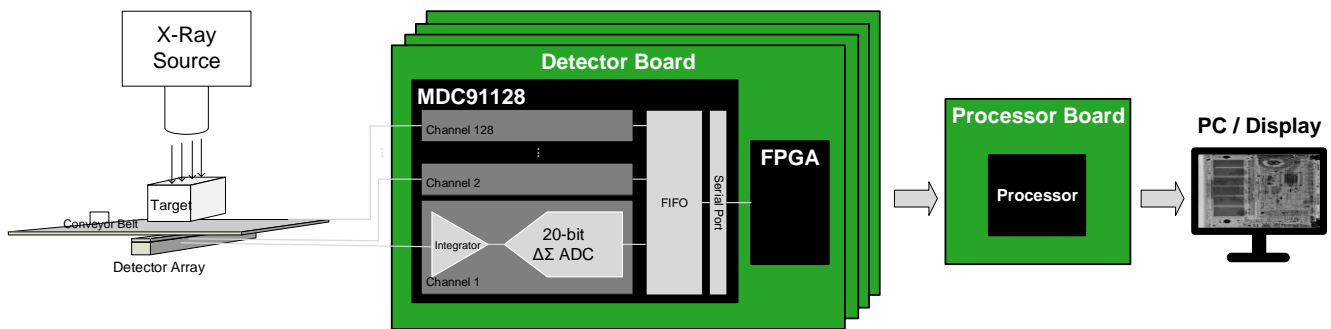

Figure 2: Scanning X-Ray Detector

As the x-rays pass through the target, they are attenuated relative to the density of the materials in their path. There are a few steps to convert x-rays to a digital representation. First, under the moving conveyor belt, a linear (1 pixel wide by many pixels long) photodiode detector array is exposed to the x-rays which pass through the target.

Because silicon photodiodes detect visible light photons much more efficiently than x-ray photons, a scintillator material is layered on top of the silicon photodiodes. This material generates visible light photons in response to x-ray excitation. The photodiode array beneath the scintillator then generates tiny electric charges proportional to that visible light.

Once the signal for each pixel is in the electrical domain, an analog/mixed signal IC can process and convert the signals to digital data. MPS’s MDC91128 can be used to directly interface to, and digitize, the photodiode array’s output.

Introducing the MDC91128

The ADC is a current input ADC with 128 parallel signal paths. Each channel comprises an amplifier and a 20-bit or 16-bit delta-sigma ($\Delta\Sigma$) ADC (see Figure 3). The MDC91128 is part of a family of [\$\Delta\Sigma\$ ADCs](#) offered by MPS.

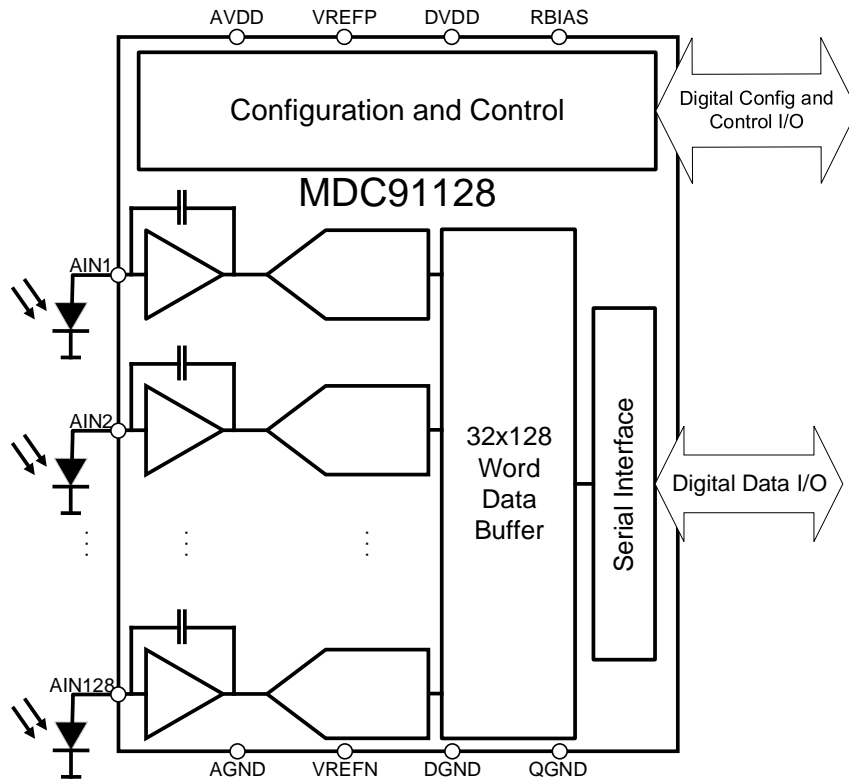

Figure 3: MDC91128 Block Diagram

The sensor array is connected such that each photodiode provides current to one of the MDC91128’s input pins. Since the average current (I) is equal to the amount of charge received (Q) divided by the integration time (t), I can be calculated with Equation (1):

$$I = \frac{Q}{t} \quad (1)$$

The input range and integration time may be selected according to the expected full-scale current. The MDC91128 supports input ranges from 4pC to 25pC, and integration times from 166 μ s to 100ms. An input of 10pC and integration time of 100ms support an average full-scale input current of 100pA. Meanwhile, an input of 25pC and integration time of 250 μ s support an average full-scale input current of 100nA. This configurability allows the MDC91128 to support applications across a wide range of signal levels.

The 128 input channels are organized into two 64-channel banks, allowing for separate control of input ranges and integration times. The integrating amplifier’s output voltage is then converted by the ADC into a selectable 16-bit or 20-bit digital result. The architecture of the MDC91128 allows back-to-back integration periods with no dead time, ensuring the full exposure is captured without loss.

When the input range is set to 25pC and the input capacitance is 20pF, the MDC91128 achieves a full-scale range, root mean square (rms) noise lower than 19ppm (see Figure 4). This is equivalent to 2,728 electrons, enabling x-ray scans with a high dynamic range.

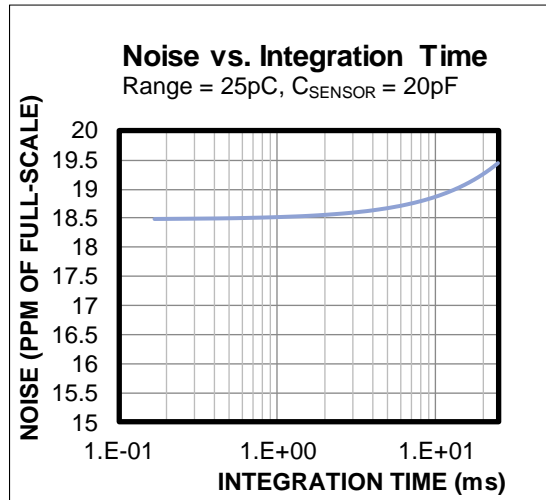

Figure 4: MDC91128 Noise Performance

The converted digital data is fed to an on-chip FIFO buffer, which is accessible via a serial port. The buffer holds 32 results (20-bit or 16-bit) for each of the MDC91128’s 128 channels. This eases system timing challenges for reading back data from the MDC91128. The serial port operates at up to 40MHz — with a dual output, it supports data transfer rates of 80Mbps.

Since scanning x-ray detectors typically require more than 128 channels, the MDC91128’s output data can be cascaded in a daisy chain. This allows the sequential readback of data from multiple MDC91128 data converter ICs in series (see Figure 5).

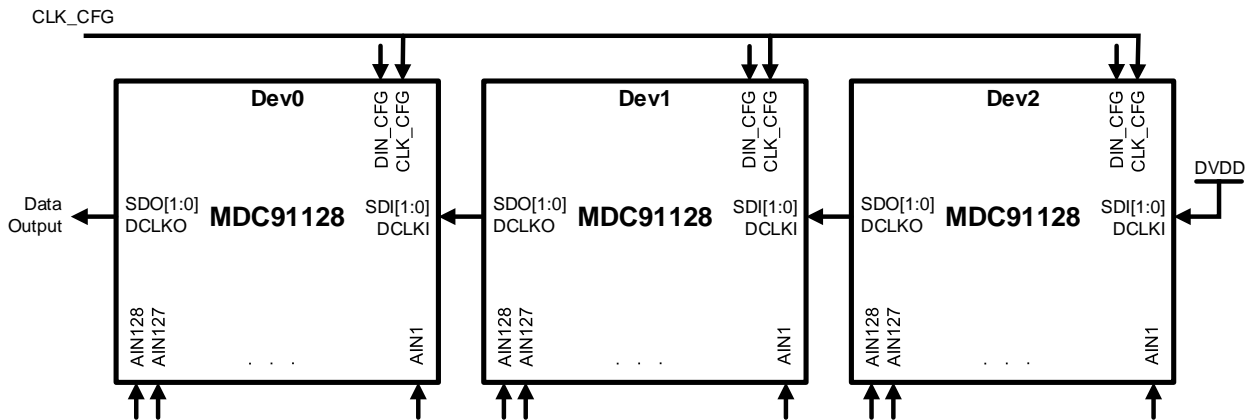

Figure 5: Cascading Multiple MDC91128 ICs

Conclusion

The [MDC91128](#) provides a combination of configurability, high performance, and integration to provide cost-effective, high-quality images for scanning x-ray systems and industrial imaging. MPS provides a growing family of [data converters](#) that can be used to x-ray imaging, data acquisition systems, and mobile communication.