

MPS

Datacenter Solutions

DC/DC Power Conversion for Datacenter, Open Compute & AI Applications



Quality Assurance & Reliability Commitment

The MPS Quality Assurance organization develops, coordinates, and champions strategic quality initiatives throughout MPS Inc., its foundries, and subcontractors. Its mission is to enable MPS to design, develop, manufacture, and deliver products to our customers with world-class quality and reliability that meet and exceed our customers' expectations.

MPS and Its Supplier Quality Systems and Certificates:

- ISO 9001:2008 (MPS)
- EU RoHS/HF/REACH Compliant (MPS)
- Sony Green Partner (MPS & Suppliers)
- TS16949 (Suppliers)
- ISO 14001 (Suppliers)

Product Quality:

- Automotive Products Qualified per AEC-Q100 Standards
- Standard Products Qualified per JEDEC and Military Standards
- Reliability Failure Rate <10FIT
- Product Quality Level <1.0ppm

Quality Control and Monitoring:

- On-Site Foundry and Assembly Teams for Real-Time Actions
- Quarterly Supplier Quality Review and Annual Supplier Audit
- Short-Term Reliability Monitoring Test – Daily
- Long-Term Reliability Monitoring Test – Monthly
- Real-Time Engineering Actions on Monitored Failures
- Quarterly Reliability Monitoring Reports

Table of Contents

Overview	4 - 5
Lateral vs. Z-Axis Power Delivery™	6
AI Form Factors	7
MPSlammer: Load Transient Tool	8
High-Voltage DC (HVDC)	9
First-Stage Solution: Power Modules	10 - 13
Second-Stage Solution: Digital Multi-Phase Controller + Intelli-Phase™ or Intelli-Modules™	14 - 23
Battery Management Overview	24
Battery Management Functional Safety	25
BMS for Datacenter Battery Backup	26
Battery Management Products	27 - 28
Why Choose MPS	30
Contact & Ordering	31

MPS Powers Every AI Socket

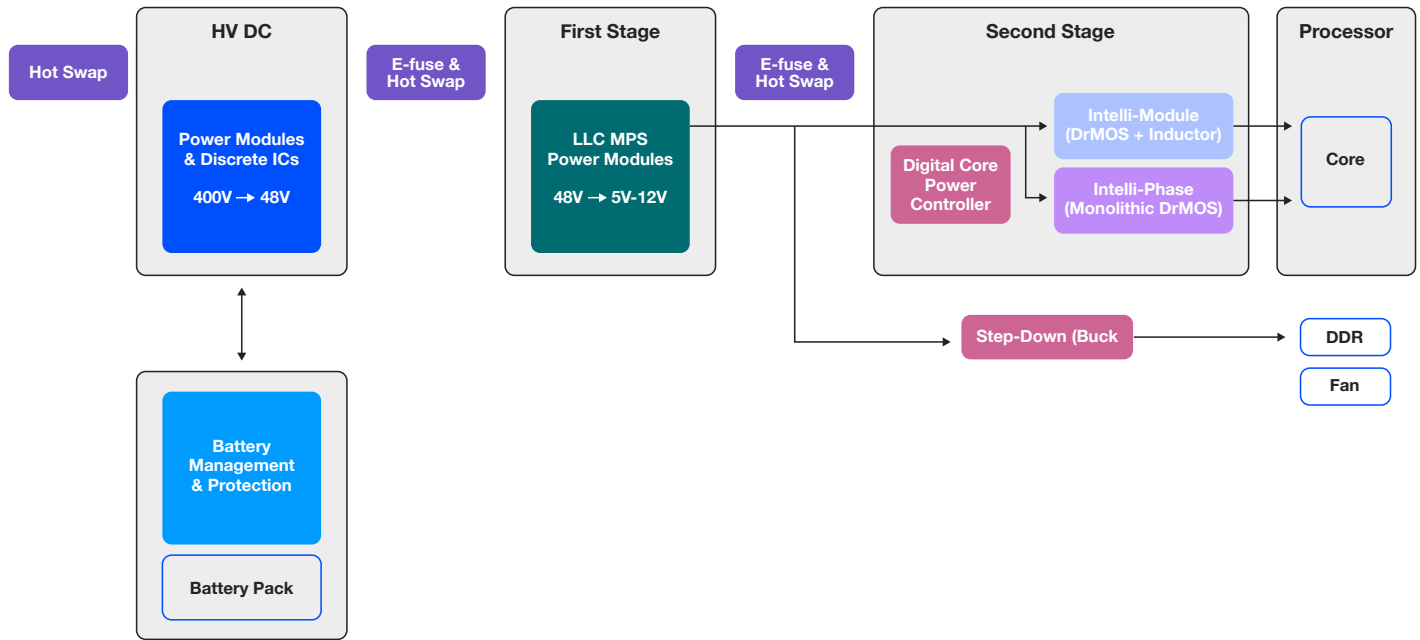

Your Engineering Partner

Defining the AI Power Ecosystem

Designing Solutions for the Toughest Challenges

Delivering to the Most Demanding Schedules

+100 AI Power Products

Solutions for All Form Factors

Power on bottom of board, top of board, and for other space-constrained configurations

Powering the Next Generation of AI Hardware

Partner with engineering teams to invent next-gen solutions

Nimble product development process allows customers to quickly iterate designs

2X speed for functional sample handoffs

Transition from 12V to 48V to HVDC

Rack Power and Distribution Voltage

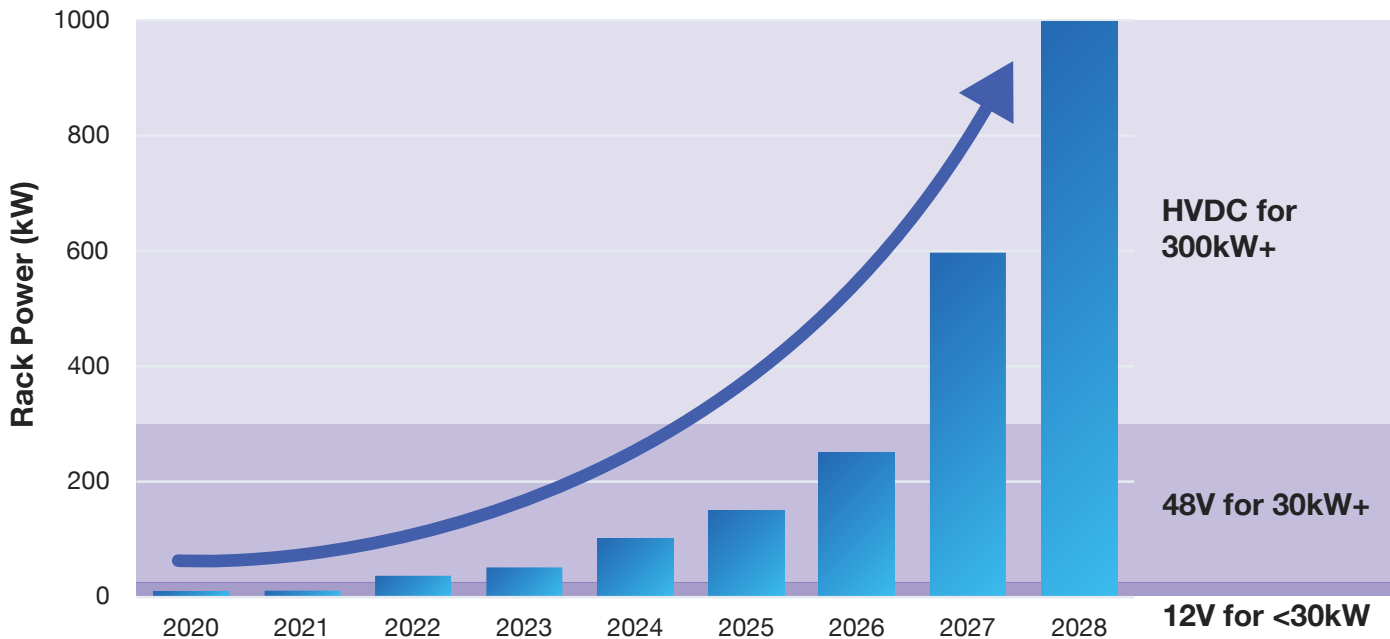

In the early 2000s, the 12V DC bus power distribution architecture was a simple and cost-effective solution for datacenters. With the continued exponential trajectory of datacenter rack power, power distribution architecture has transitioned from 12V DC to 48V DC, and is now transitioning to high-voltage DC (HVDC).

As rack power began to exceed 30kW, power distribution architecture transitioned from 12V DC to 48V DC bus to improve overall system efficiency by reducing I²R loss, streamlining power conversion by removing redundant conversion stages, and enabling higher rack density by reducing component size.

As rack power continues on to exceed 300kW, the industry is transitioning to HVDC power distribution architecture to further improve end-to-end system efficiency by eliminating intermediate conversion steps, reducing cost by decreasing copper required for busbars and cabling, and improving datacenter floor space utilization.

Lateral vs. Z-Axis Power Delivery™ (ZPD™)

Today's datacenters use a lateral power delivery system, in which the power voltage regulators are placed on the top side of the board around the processor. As the current demands of CPUs and GPUs increase, the distance between the voltage regulator and the point-of-load (PoL) become a significant factor for power delivery network (PDN) losses. In addition, increased PDN means that the system requires a large amount of output capacitance for the voltage regulators.

Z-Axis Power Delivery™ (ZPD™) is a method by which the voltage regulators are placed on the bottom side of the PCB below the processors. This results in a significant reduction (more than 5X) in PDN losses.

Lateral Power Delivery <1000A

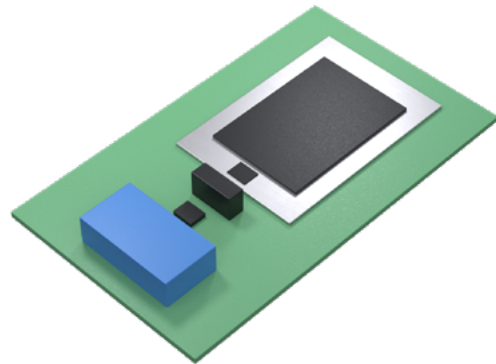

Z-Axis Power Delivery™ >1000A

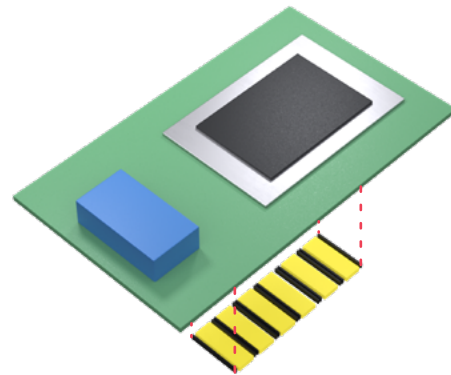

MPS offers power module solutions with <5mm height to fit in the limited space on the bottom side of the PCB.

Contact MPS for more information on Z-Axis Power Delivery™ EVBs

AI Form Factors

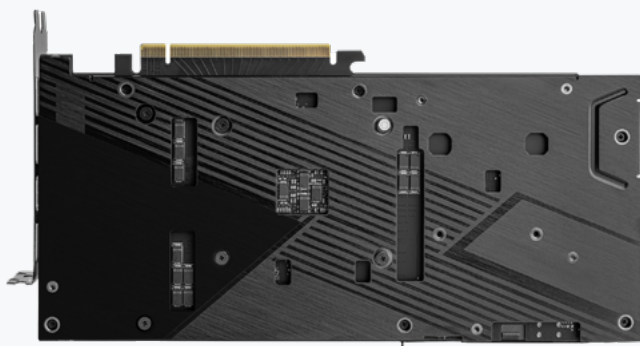
**PCIe Accelerator**

Power:
~300W

V_{IN}:
12V

Featured Solutions:
E-Fuse and Hot Swap
Multi-Phase Controllers
Intelli-Phase™
Intelli-Module™
Point-of-Load (POL)

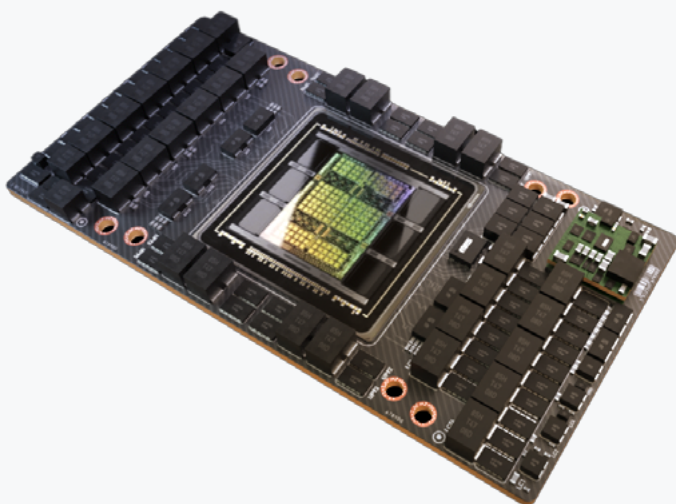
**OAM**

Power:
750kW to 1.5W

V_{IN}:
54V

Featured Solutions:
E-Fuse and Hot Swap
IBC Modules
Multi-Phase Controllers
Intelli-Phase™
Intelli-Module™
Point-of-Load (POL)

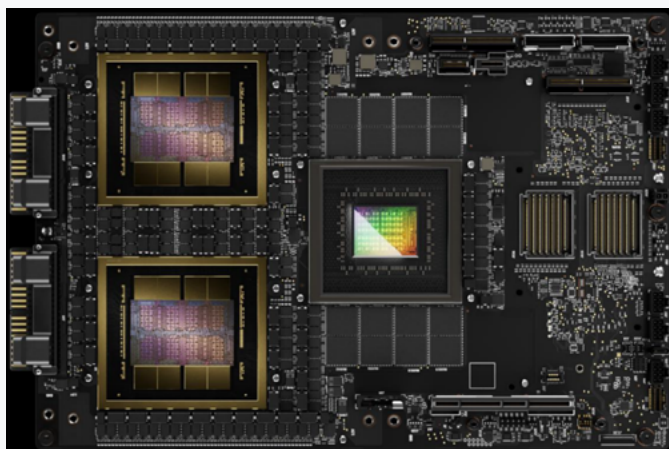
**Motherboard + PDB:**

Power:
>1.5kW

V_{IN}:
Power Delivery Board (PDB): 54V or >400V
Motherboard: 12V

Featured Solutions:
HVDC Hot Swap
HVDC IBC Modules
Multi-Phase Controllers
Intelli-Phase™
Intelli-Module™
Point-of-Load (POL)

MPSlammer: Load Transient Tool

The MPSlammer is designed to be an easy-to-use and cost-effective method to evaluate MPS power solutions in customer designs.

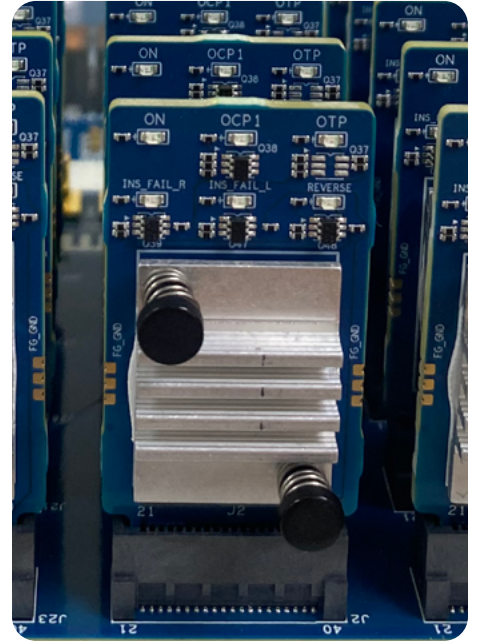
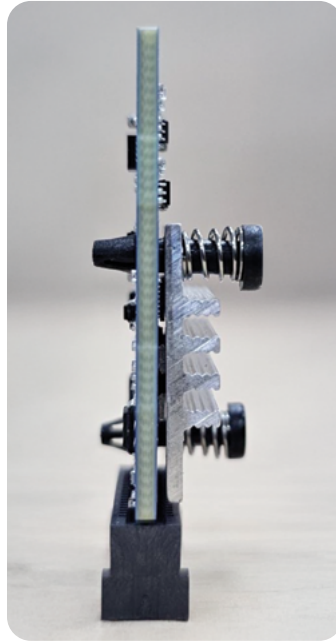
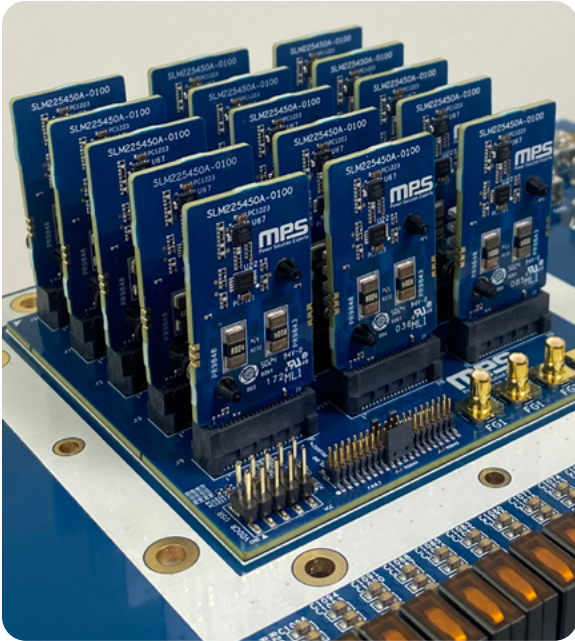

MPSlammer 3D Transient Plot Example:

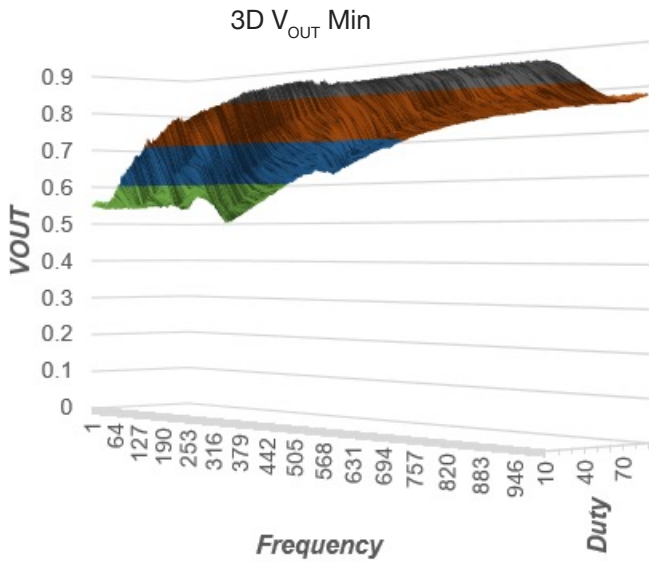

Features

- 100A Peak Current (AC Only)
- Minimum Rise/Fall Time: 130ns
- Max di/dt: 769A/ μ s
- Stackable
- Reuseable
- Reverse Insertion Protection
- Bad Insertion Protection
- Over-Temperature Protection (OTP)
- Over-Current Protection (OCP)
- MPS GUI
 - Auto-Test Mode: Sweep Load Frequency and Load Duty Cycle
 - Automatic 3D Transient Test Plots

High-Voltage DC (HVDC)

MPS's HVDC hot-swap solutions are designed to support two-wire or three-wire connections into the $\pm 400\text{V}$ ecosystem. Figure 1 shows an example application with a two-wire connection and 800V conversion modules.

$\pm 400\text{V}$, 2-Wire with 50V to 800V 16:1 Modules

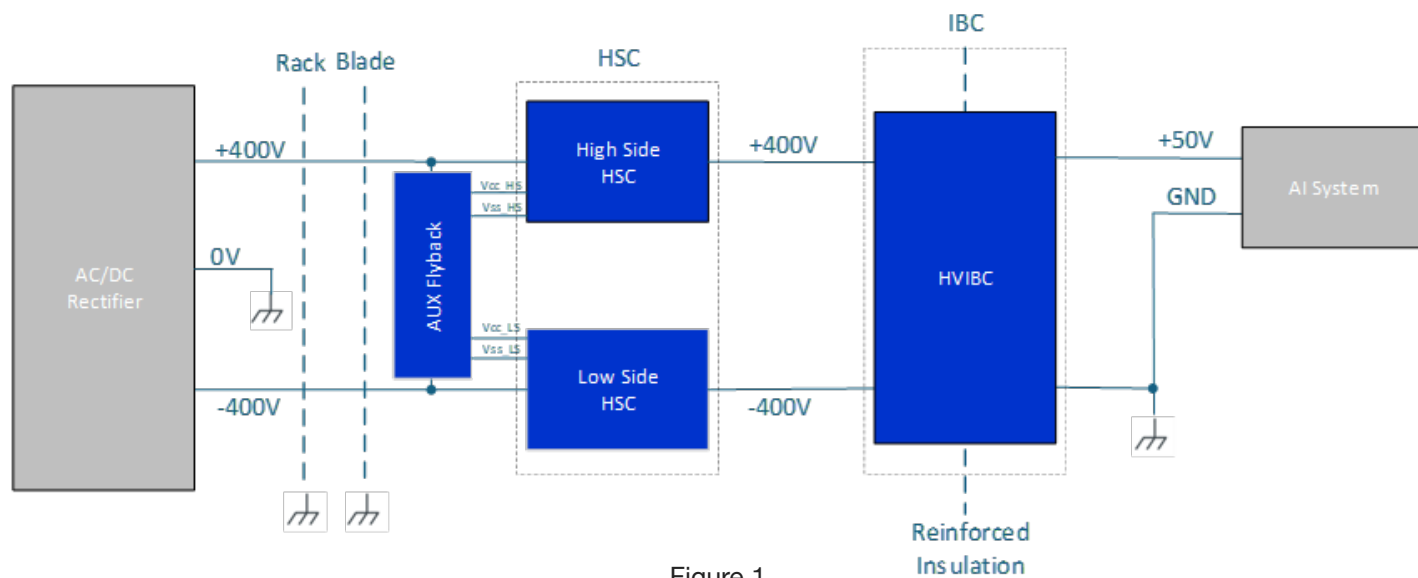
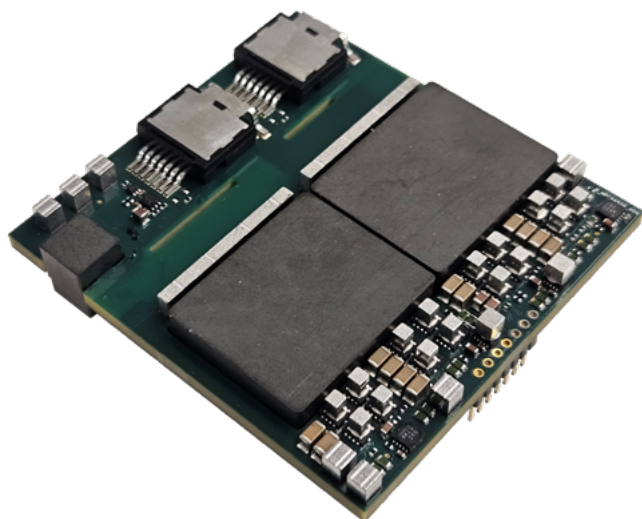

Figure 1

MPC34500



Features

- Input Voltage (V_{IN}) = 800V, Output Voltage (V_{OUT}) = 50V, 6kW
- Unregulated and Reinforced Isolation
- Half-Brick
- 65mmx61mmx10.8mm
- 98.4% Efficiency at Room Temperature
- 2,317W/in³
- IEC 62368-1 Compliant

First-Stage Solution: Power Modules

MPS Offers Multiple Options for First-Stage Modules

8:1 and 10:1 IBC Modules

54V to 6.75V, or 5.4V

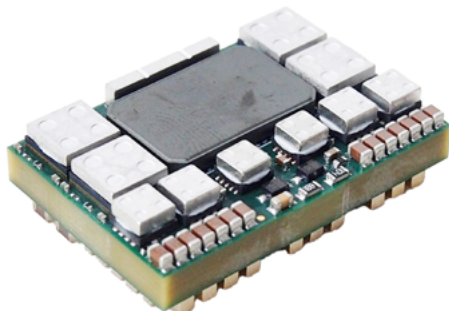

Enables a higher-frequency second stage due to lower switching losses, which allows the use of a smaller, shorter inductor.

- Best for Z-Axis Power Delivery™ (ZPD™)

4:1 IBC Modules

54V to 13.5V



Higher power density, established common footprint in the market.

- Best for lateral power delivery (LPD)

Regulated Modules

54V to 12V



Targeted for systems such as CPU servers that require a regulated 12V supply

All of MPS's IBC modules can be paralleled to reach >1kW power levels.

MPC10106-B-54-0500

High-Efficiency, Non-Isolated, Fixed-Ratio, Digital DC/DC 600W Power Module

The MPC10106-54-0500 is an open-frame digital DC/DC power module with up to 600W of continuous power. This module accepts up to a 60V input, and is configured in an 8:1 input-to-output ratio. The microcontroller unit (MCU) can store device configurations and status. The fault status, input voltage (V_{IN}), output voltage (V_{OUT}), current, and temperature can be monitored via the communication interface.

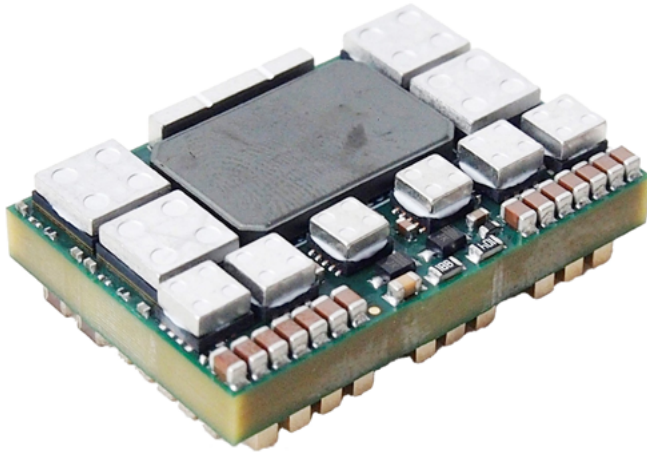

Features

- 40V to 60V Input Voltage (V_{IN}) Range
- 8:1 Input-to-Output Ratio
- Power Level: Up to 500W
- Power Density: 3019W/in³
- LLC Topology
- MCU Communication Interface
- Built-In Multiple-Time Programmable (MTP) Memory to Store Custom Configurations
 - V_{IN} Under-Voltage Lockout (UVLO)
 - Output Voltage (V_{OUT}) Over-Voltage Protection (OVP) and Under-Voltage Protection (UVP)
 - OCP_TDC/SPIKE
 - Over-Temperature Protection (OTP)

Dimensions

27mmx18mmx6.7mm

Part Number	V_{IN} (V)	V_{OUT} Range (V)	Power Density (W/in ³)	P_{OUT} (W)	Peak Efficiency (%)	Efficiency at 600W (%)
MPC10106-B-54-0500	40 to 60	5 to 7.5	3019	500	97.65	96.59

MPC12106-54-0750

4:1 Fixed-Ratio, Digital, DC/DC 800W Power Module

The MPC12106-54-0750 is an open-frame, digital DC/DC power module with continuous power up to 750W. This module accepts up to a 60V input, and is configured in a 4:1 input-to-output ratio. It offers a digital controller with a multiple-time programmable (MTP) memory, which can be easily configured to quickly bring up the system and nimbly adapt to system requirements.

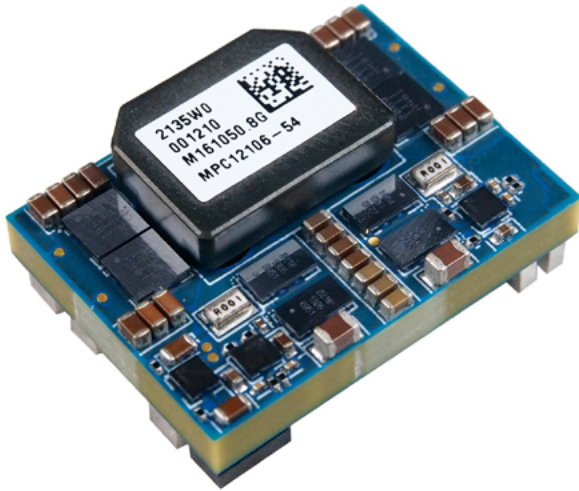

Features

- Input Voltage (V_{IN}) Range: 40V to 60V
- 4:1 Input-to-Output Ratio
- Power Density: 3310W/in³
- Non-Isolated LLC Topology
- Compatible with Serial Interface
- Built-In Multiple-Time Programmable (MTP) Memory to Store Custom Configurations
 - V_{IN} Under-Voltage Lockout (UVLO)
 - V_{OUT} Over-Voltage Protection (OVP) and Under-Voltage Protection (UVP)
 - OCP_TDC/SPIKE
 - Over-Temperature Protection (OTP)
- GUI Configuration Software Provided

Dimensions

24mmx18mmx8.6mm

Part Number	V_{IN} (V)	V_{OUT} Range (V)	Power Density (W/in ³)	P_{OUT} (W)	Peak Efficiency (%)	Efficiency at 750W (%)
MPC12106-54-0750-xxxx	40 to 60	10 to 15	3310	750	98.1	96.5

MPC42013

High-Efficiency, Non-Isolated, Regulated, Digital DC/DC 1300W and 1600W Power Module

The MPC42013 is a quarter-brick open-frame digital DC/DC power module with up to 1300W or 1600W of continuous power. This module operates from a 40V to 60V DC primary bus to a regulated 12V output voltage (V_{OUT}). It offers a digital controller with multiple-time programmable (MTP) memory, which can be easily configured to quickly bring up the system and nimbly adapt to system requirements.



Features

- 40V to 60V Input Voltage (V_{IN}) Range
- 12V Regulated Output Voltage (V_{OUT})
- Power Level: Up to 1300W or 1600W
- Power Density: 906W/in³ or 736W/in³
- HSC Topology
- Compatible with Serial Interface
- Option for Load-Line Current-Sharing in Parallel or Differential Remote Sense
- Built-In Multiple-Time Programmable (MTP) Memory to Store Custom Configurations
 - V_{IN} Under-Voltage Lockout (UVLO)
 - V_{OUT} Over-Voltage Protection (OVP) and Under-Voltage Protection (UVP)
 - Over-Current Protection (OCP)
 - Over-Temperature Protection (OTP)
- GUI Configuration Software Provided

Dimensions

27mmx18mmx6.7mm

Part Number	V_{IN} (V)	V_{OUT} Range (V)	Power Density (W/in ³)	P_{OUT} (W)	Peak Efficiency (%)	Full Load Efficiency (%)
MPC42013-54-1300	40 to 60	12	736	1300	97.7	97.1
MPC42013-54-1600	40 to 60	12	906	1600	97.8	97

Second-Stage Solution: Digital Multi-Phase Controller + Intelli-Phase™ or Intelli-Module™

MPS has a robust product portfolio of digital, multi-phase controllers that are paired with Intelli-Phase™ and Intelli-Module™ devices for a complete second-stage solution.

For more information, visit <https://www.monolithicpower.com/en/powering-ai-hardware>

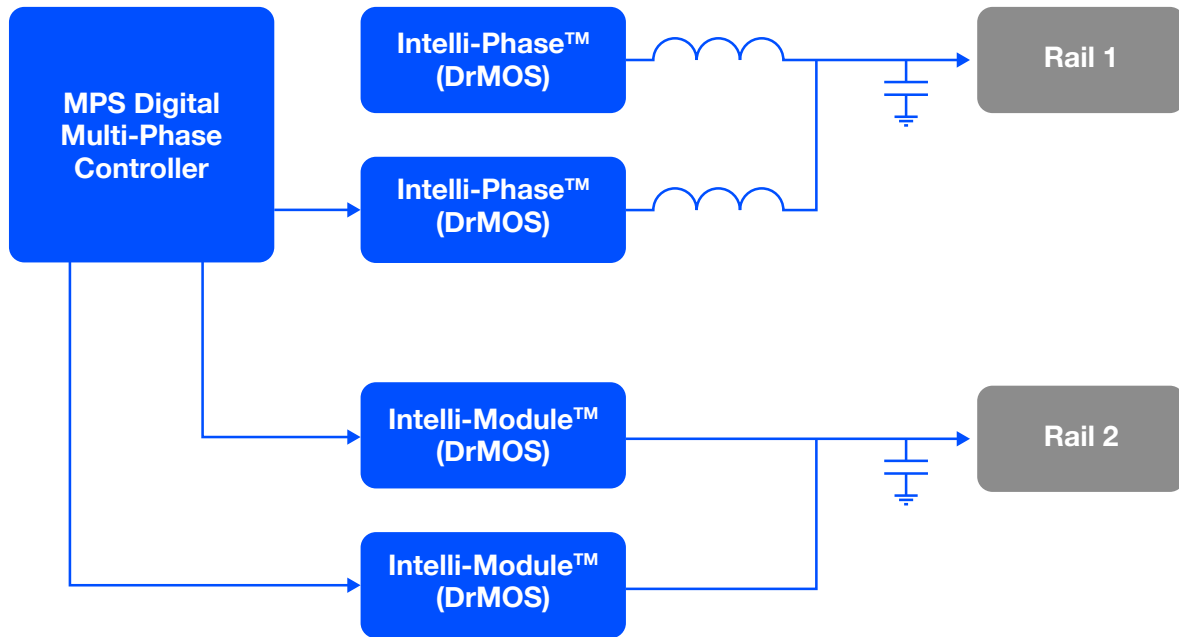

Digital Multi-Phase Controller Features:

- Patented Constant-On-Time (COT) Control
- Multiple Loops, Flexible Phase Assignment
- Interface Options: SVID, SVI2/3, OVR, or AVSBus
- Fault Handling and Telemetry Capabilities

Part Number	Description
MP2975	2-Loop, 8-Phase Digital Controller
MP29816-C	2-Loop, 16-Phase Digital Controller
MP2928	3-Loop, 12-Phase Digital Controller

Intelli-Phase™ Features:

- 12A to 100A Range across Family of Devices
- Wide Switching Frequency (f_{sw}) Range Provides Balance between Transient and Efficiency
- Built-In Zero-Current Detection (ZCD), Over-Current Protection (OCP), Negative OCP (NOCP), Over-Temperature Protection (OTP), and Short-Circuit Protection (SCP)
- Minimal External Components

Part Number	Description
MP87297	16V, 100A, 4mmx6mm
MP87190	16V, 90A, 5mmx6mm
MP87563	16V, Dual 60A, 5mmx5mm

Intelli-Module™ Features:

- High Power Density in Space-Constrained Applications
- Flexible Output Assignment
- Supports Parallel Operation for Higher Power Delivery
- Optimized for Top-Side Cooling

Part Number	Description
MPC22157-A-130	130A Module, 9mmx10mmx8mm
MPC22158-130	130A Module, 8mmx8mmx4mm
MPC24380-260	260A Module, 9mmx10mmx5mm

MPC22158-130

130A, Two-Phase Intelli-Module™ with Quiet Switcher™ Technology (QST™)

The MPC22158 is a non-isolated, step-down power module with up to 130A of continuous peak output current (I_{OUT}). This module integrates driver MOSFETs and an inductor in a compact package to save layout space and achieve higher power density. It has two independent outputs, which can be used separately or in parallel. The 4mm maximum height makes it suitable for many applications, such as Z-Axis Power Delivery™ (ZPD™) and PCIe form factor boards.



Features

- 3V to 16V Input Voltage (V_{IN}) Range
- 0.5V to 2V Output Voltage (V_{OUT})
- 130A Output Current (I_{OUT})
- Accu-Sense™ Current Sense
- Temperature Sense
- Over-Current Protection (OCP)
- Over-Temperature Protection (OTP)
- Supports Parallel Operation
- Fault Reporting
- Available in a Common-Footprint LGA-45 (8mmx8mm) Package

Dimensions

8mmx8mmx3.8mm

Part Number	V_{IN} (V)	V_{OUT} Range (V)	I_{OUT} (A)	f_{sw} (kHz)	Current Density (A/mm ²)	Peak Efficiency (%)
MPC22158-130	3 to 16	0.5 to 2	130	600 to 1500	1.6	90

MPC22166-D-130

130A, Dual-Phase Intelli-Module™ with Quiet Switcher™ Technology (QST™)

The MPC22166-D is a non-isolated, step-down power module with up to 130A of continuous peak output current (I_{OUT}). This module integrates driver MOSFETs and an inductor in a compact package to save layout space and achieve higher power density. It has two independent outputs, which can be used separately or in parallel. The 5mm maximum height makes it suitable for many applications, such as Z-Axis Power Delivery™ (ZPD™) and PCIe form factor boards.



Features

- 3V to 16V Input Voltage (V_{IN}) Range
- 0.2V to 2V Output Voltage (V_{OUT})
- 130A Output Current (I_{OUT})
- Accu-Sense™ Current Sense
- Temperature Sense
- Over-Current Protection (OCP)
- Over-Temperature Protection (OTP)
- Supports Parallel Operation
- Fault Reporting
- Available in a Common-Footprint LGA-72 (9mmx10mm) Package

Dimensions

9mmx9.9mmx4.75mm

Part Number	V_{IN} (V)	V_{OUT} Range (V)	I_{OUT} (A)	f_{SW} (kHz)	Current Density (A/mm ²)	Peak Efficiency (%)
MPC22166-D-130	3 to 16	0.2 to 2	130	400 to 2000	1	91

MPC22175-130

130A, Dual-Phase, TLVR Intelli-Module™ with Quiet Switcher™ Technology (QST™)

The MPC22175 is a non-isolated, step-down trans-inductor voltage regulator (TLVR) power module with up to 130A of continuous peak output current (I_{OUT}). This module integrates driver MOSFETs and an inductor in a compact package to save layout space and achieve higher power density. It has two independent outputs, which can achieve parallel layout and operation with the TLVR footprint. The 5mm maximum height makes it suitable for many applications, such as Z-Axis Power Delivery™ (ZPD™) and PCIe form factor boards.

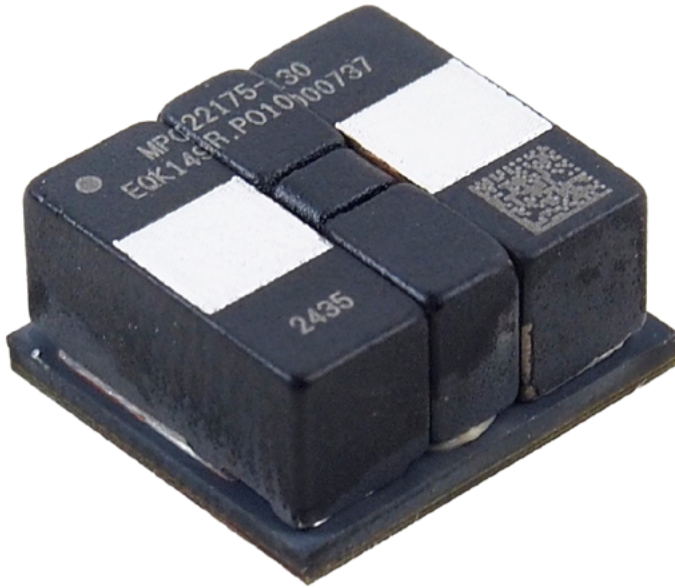

Features

- 4V to 16V Input Voltage (V_{IN}) Range
- 0.2V to 2V Output Voltage (V_{OUT})
- 130A Output Current (I_{OUT})
- Accu-Sense™ Current Sense
- Temperature Sense
- Over-Current Protection (OCP)
- Over-Temperature Protection (OTP)
- Supports Parallel Operation
- Fault Reporting
- Available in a Common-Footprint LGA-72 (9mmx10mm) Package

Dimensions

9mmx9.9mmx4.75mm

Part Number	V_{IN} (V)	V_{OUT} Range (V)	I_{OUT} (A)	f_{sw} (kHz)	Current Density (A/mm ²)	Peak Efficiency (%)
MPC22175-130	4 to 16	0.2 to 2	130	400 to 2000	1	89

MPC24380-260

260A, Four-Phase Intelli-Module™ with Quiet Switcher™ Technology (QST™)

The MPC24380 is a non-isolated, step-down power module with up to 260A of continuous peak output current (I_{OUT}). This module integrate driver MOSFETs, an inductor, and an output capacitor to provide high efficiency in a small footprint. The 5mm maximum height makes it suitable for many applications, such as Z-Axis Power Delivery™ (ZPD™) and PCIe form factor boards.

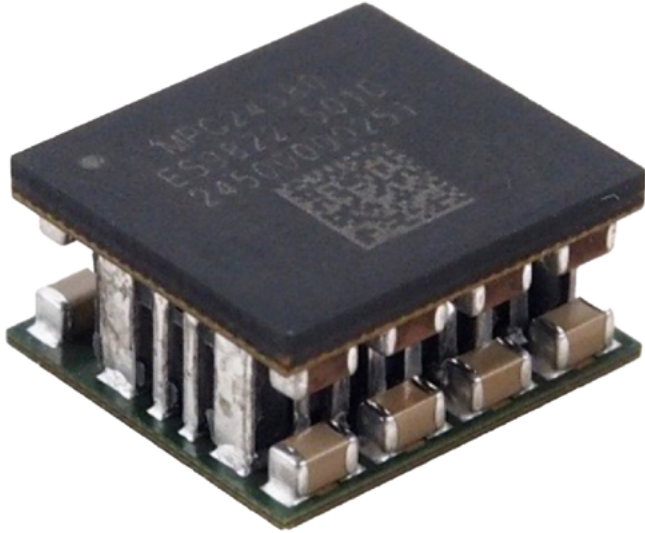

Features

- 3V to 8V Input Voltage (V_{IN}) Range
- 0.5V to 2V Output Voltage (V_{OUT})
- 260A Output Current (I_{OUT})
- Accu-Sense™ Current Sense
- Temperature Sense
- Over-Current Protection (OCP)
- Over-Temperature Protection (OTP)
- Fault Reporting
- Available in a Common-Footprint LGA-54 (9mmx10mm) Package

Dimensions

9mmx9.9mmx4.75mm

Part Number	V_{IN} (V)	V_{OUT} Range (V)	I_{OUT} (A)	f_{SW} (kHz)	Current Density (A/mm ²)	Peak Efficiency (%)
MPC24380-260	3 to 8	0.5 to 2	260	500 to 1500	2	91

MP29816-C

16-Phase, Dual-Loop Digital Controller

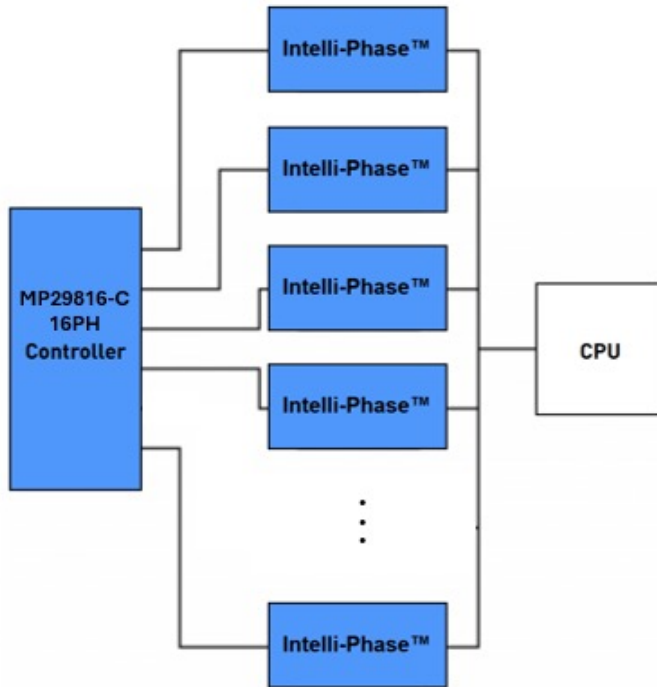

Features

- Automatic Loop Compensation
- Supports 200kHz to 3MHz Switching Frequency (f_{sw})
- Multi-Configuration Function Supports Up to 6 Different Applications
- Flexible PWM Assignment for 2 Rails
- Flexible Output Current (I_{OUT}) Sense via DrMOS I_{OUT}
- Automatic Phase-Shedding (APS) Function Improves Overall Efficiency
- Phase-to-Phase Active Current Balancing with Configurable Offsets for Thermal Balance
- Input Voltage (V_{IN}), Output Voltage (V_{OUT}), Current, and Power Monitoring
- V_{IN} Under-Voltage Lockout (UVLO), Output Over-Voltage Protection (OVP) and Under-Voltage Protection (UVP), Over-Current Protection (OCP), Over-Temperature Protection (OTP) with No Action, Latch-Off, and Hiccup Options
- Overclocking Mode by Adding Offset to V_{OUT}
- Available in a TQFN-56 (7mmx7mm) Package

MPQ82D00

16V, 20A, High-Efficiency, Synchronous Step-Down Converter with Integrated Telemetry via PMBus

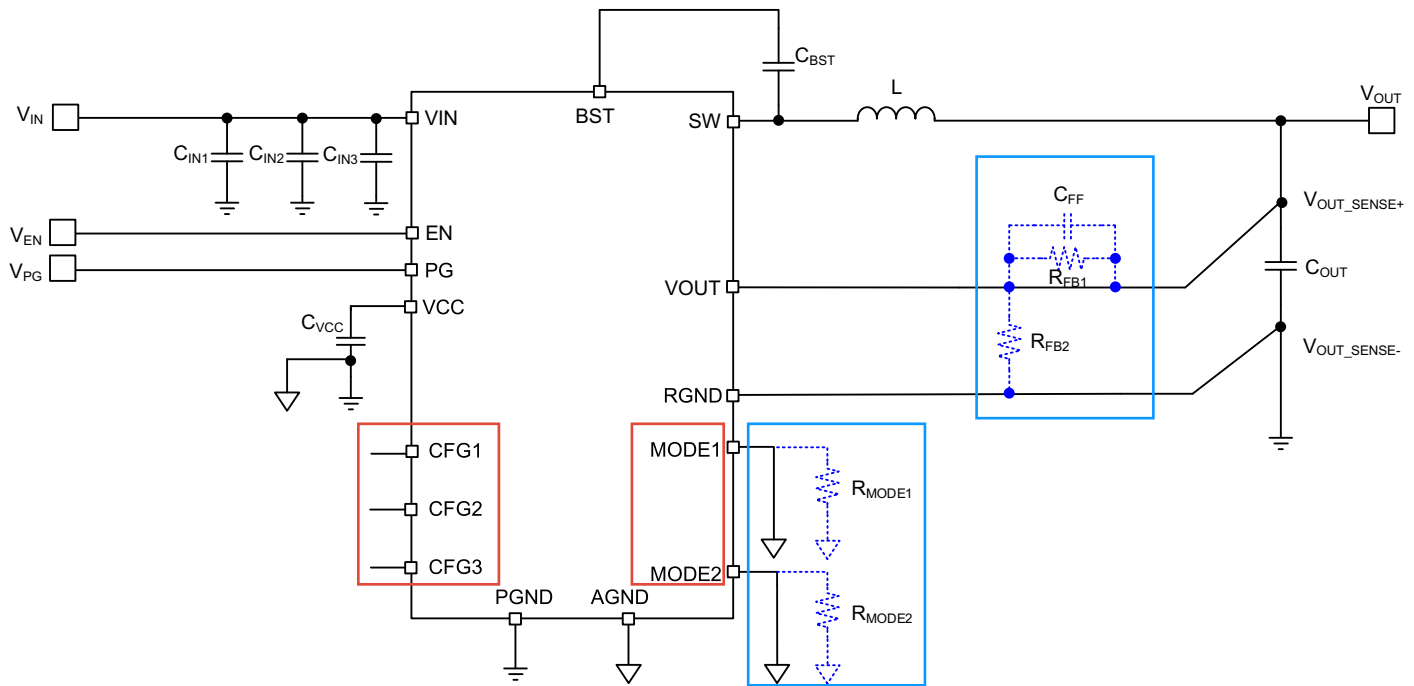

BOM-Free Mode = No External Components
 External FB Mode = More Settings Options

Features

- 2.7V to 16V Input Voltage (V_{IN}) with External 3.3V VCC Voltage (V_{CC})
- 20A Continuous Output Current (I_{OUT})
- 0.3V to 5.5V Output Voltage (V_{OUT})
- Adaptive Constant-On-Time (COT) Control for Ultra-Fast Transient Response
- BOM-Free Configuration Option
- $\pm 0.5\%$ Reference Voltage (V_{REF}) from -40°C to $+150^{\circ}\text{C}$
- Selectable 600kHz, 800kHz, 1MHz, or 1.2MHz Switching Frequency (f_{SW})
- PMBus V1.4 Compliant
- Register Read/Write (R/W) Protection for Security
- Hiccup or Latch-Off Over-Current Protection (OCP), Under-Voltage Protection (UVP), Temperature Protection (OTP), Over-Voltage Protection (OVP)
- 5% V_{OUT} and I_{OUT} Accuracy
- Black Box to Record Fault Information
- Remote Sense

MP5930

80V Hot-Swap and O-Ring Controller with PMBus Interface

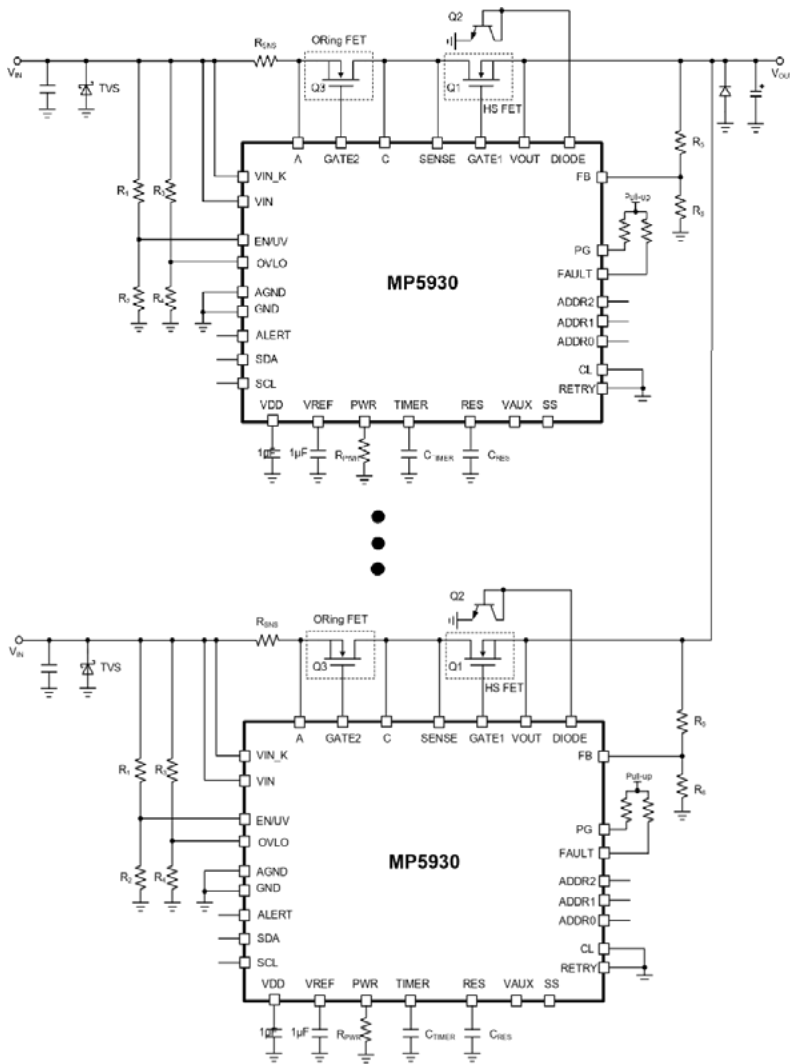

Features

- Supports Ideal Diode and E-Fuse Back-to-Back Structure
 - Reverse Current Blocking and Protection
 - Configurable Over-Current Protection (OCP)
 - Configurable Power Limit
 - Configurable Short-Circuit Protection (SCP)
 - Configurable Soft Start (SS) Current Limit
 - Configurable Over-Temperature Protection (OTP)
 - Configurable Soft Start Time (t_{SS})
- PMBus Interface
 - Configurable Device Configuration via the PMBus
 - 12-Bit Analog-to-Digital (ADC) to Monitor Input Voltage (V_{IN}), Output Voltage (V_{OUT}), Output Current (I_{OUT}), Aux Voltage (V_{AUX}), and Temp Voltage (V_{TEMP}) via the PMBus

Multiple Power Supplies Can Be Paralleled Together with Each MP5930 in Back-to-Back Mode

- The O-ring FET allows paralleling multiple supplies
- The HS-FET allows for all e-fuse protections
- Combining both allows the ability to completely isolate V_{IN} from V_{OUT} in both directions

MP593D0

80V, 20A, 4mΩ $R_{DS(ON)}$, Fully Integrated Hot-Swap Solution with PMBus Interface

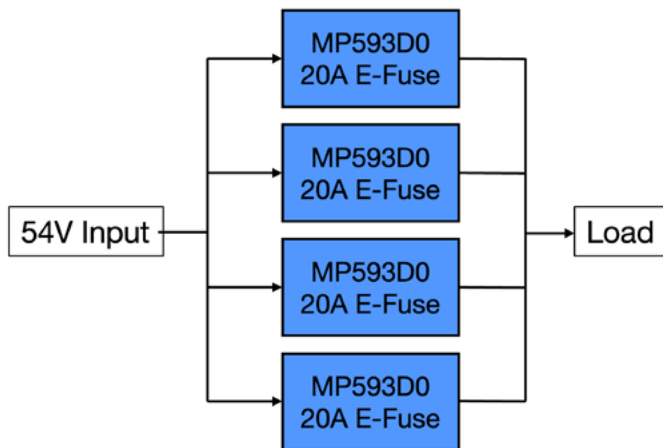

Supports >4000W Application Using
4 MP593D0 Devices in Parallel

Features

- 10V to 80V Operating Input Voltage (V_{IN}) Range
- Maximum 20A Output Current (I_{OUT})
- 4mΩ Integrated Power MOSFET
- $\pm 3\%$ IMON Reporting Accuracy
- PMBus/I²C 1.3 Compatible
- Full Protection Functions:
 - Over-Current Protection (OCP), Output Short-Circuit Protection (SCP), Over-Temperature Protection (OTP), Over-Voltage Protection (OVP), and Under-Voltage Protection (UVP)
- Separate Current-Sense Output Used to Configure the Over-Current (OC) Threshold
- Built-In Soft Start (SS) and Insertion Delay
- Output Voltage (V_{OUT}) Shutdown Control
- Parallel Operation for Higher-Current Applications
- Integrated Current, Voltage, and Temperature Sensing
- Supports Complete Protection Function for the System
- Built-In Fuse Health Diagnostics

MP87563

Dual 60A DrMOS with Quiet Switcher™ Technology (QST™)

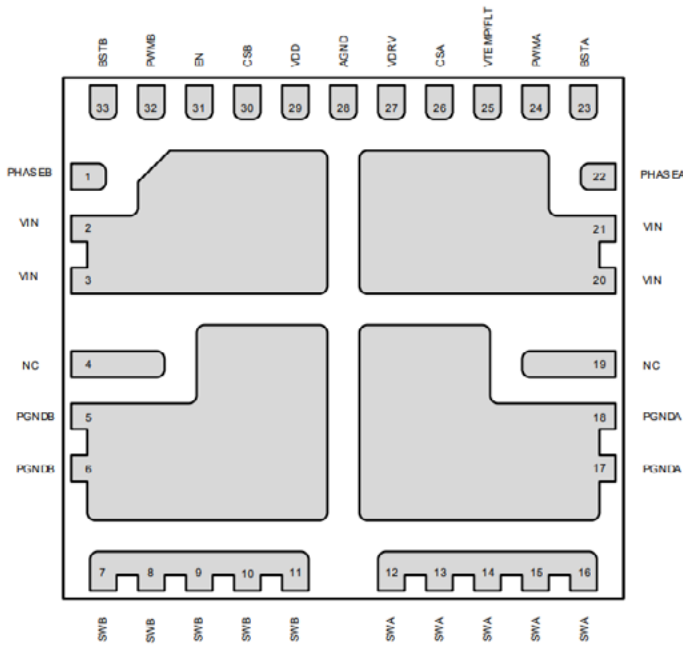

LGA-33 (5.25mmx5mm) Package

Features

- Wide 3V to 16V Operating Input Voltage (V_{IN}) Range
- Up to per-Phase 60A Output Current (I_{OUT})
- Highest Power Density with Smallest Placement Area
- 3.3V V_{DD}/V_{DRV} Operation for Best Efficiency
- Junction Temperature (T_J) Sense
- Per-Phase Accurate Current Reporting
- Available in a Common Footprint TLGA-33 (5.25mmx5mm) Package

Placement Benefit

Conditions: 50% Area Reduction Using the MP87563 in a 700A Application

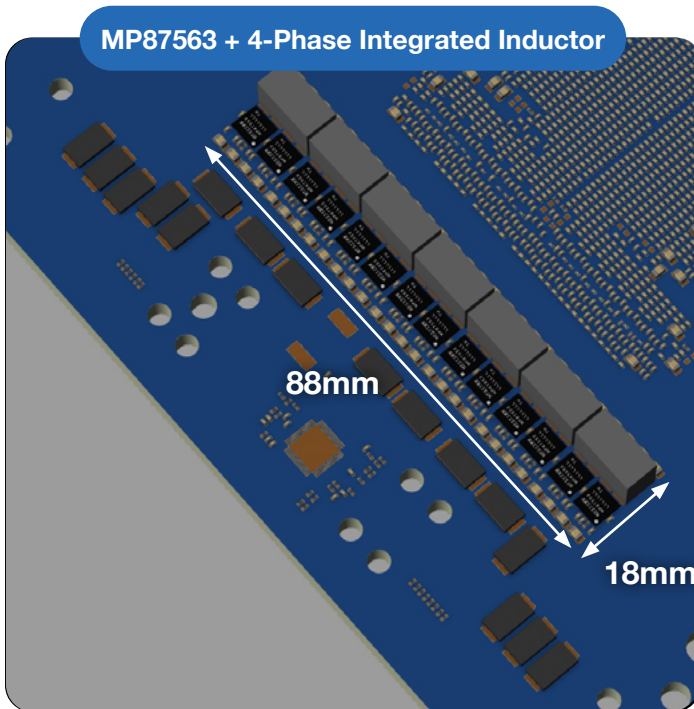

MP87563:
60A+60A Part, TDC 25+25A
28 Phases Needed Total/14pcs

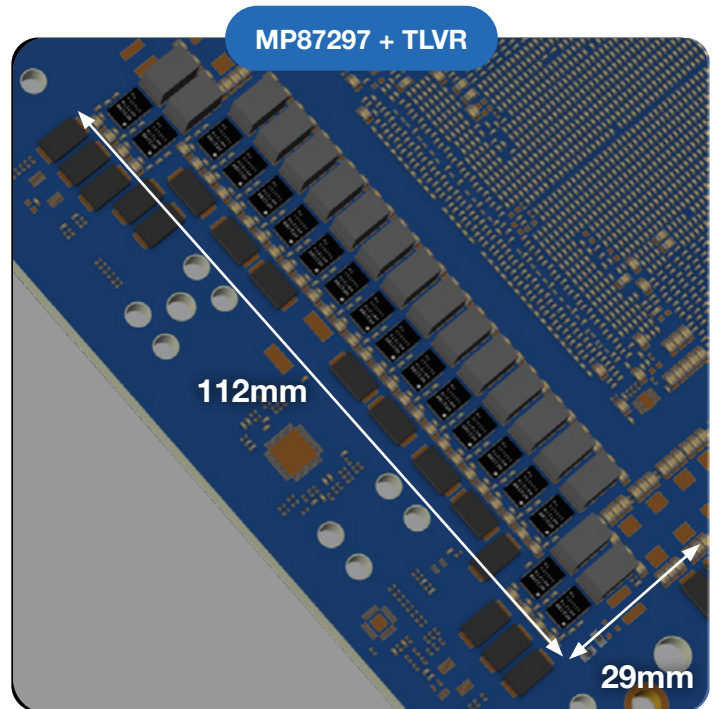

MP87297:
100A Part, TDC 40A
18 Phases Needed Total

MPS Battery Management Solutions

Active Balancers

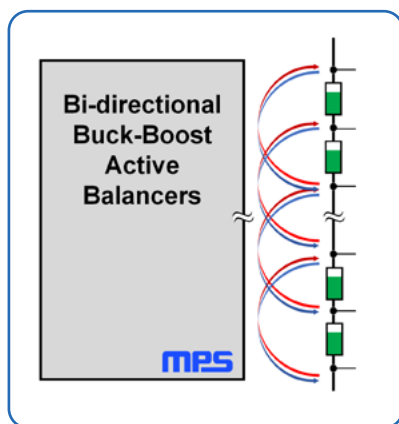

Battery Monitors

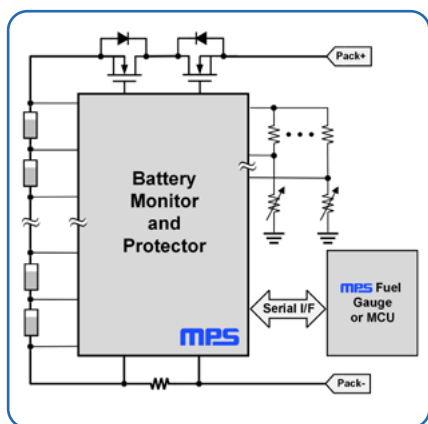

Fuel Gauges

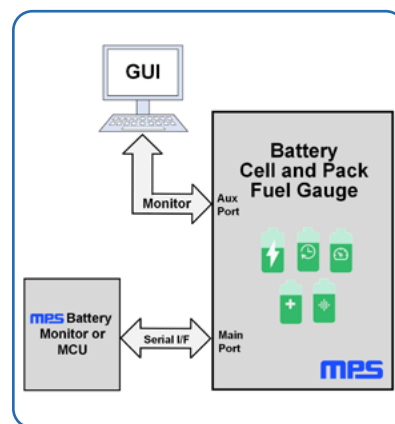

BMS Complete Solutions

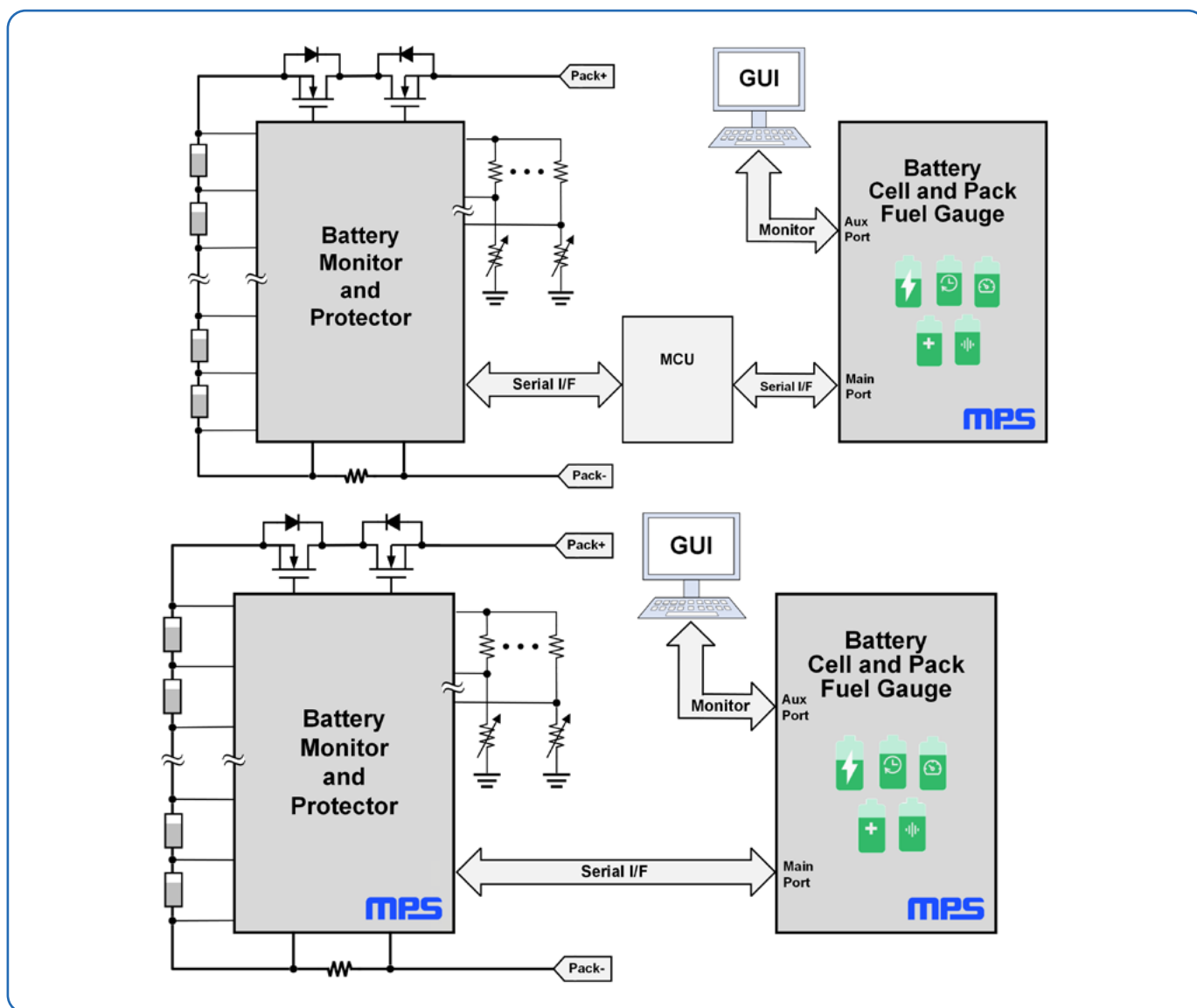

MPS Functional Safety Concept

ISO 13849 PL-C Architecture Certified

MPS's functional safety concept uses a redundancy architecture in which the MCU senses key parameters for the battery and for the battery monitor and protector to ensure correct functioning. A PL-C functional safety level can be achieved with MPS's safety concept.

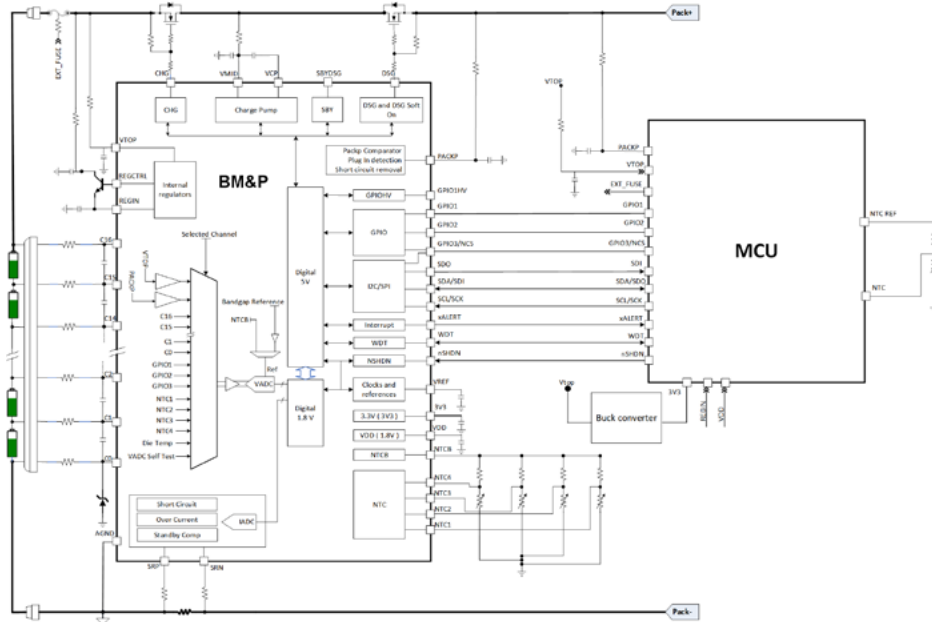

Your Need

MPS Advantage

A Complete BMS Solution

Fully Validated Comprehensive Design

Meet Functional Safety Requirements

Pre-Certified FuSa-Ready Architecture

Straightforward Implementation

MPS's Dedicated FuSa Software

Customizable Hardware

Hardware Schematics Provided

Minimal Design and Schedule Risk

Reference Designs and Complete Solutions Available

BMS for Datacenter Battery Backup Units (BBUs)

Applications Characteristics

- Current systems typically use 48V to 54V; new high-power systems are targeting 400V to 800V
- Battery reliability is critical to product success
 - Systems subject to “rarely used pack” condition
 - State-of-health (SOH) must be periodically assessed to guarantee uptime
 - System must always know the available energy and power with high accuracy
- Evolving architectures for growing power requirements
 - Two common voltage ranges: 48V and 400V to 800V
 - Rack-mount and floor-mount systems
 - Integration of supercapacitors for peak-shaving
- Commonly requires high discharge rates (15C+)
 - Accurate fuel gauging becomes increasingly important and difficult
 - MOSFET-based current control requires parallel devices with very strong charge/discharge drive capability



MPS Advantages

- Battery Monitors
 - Enable outstanding product reliability and lifetime via high-accuracy, I/V synchronized measurements
 - Very strong drive capacity, up to 10X the leading competitor, which is particularly important for short-circuit protection (SCP)
 - Support LFP, Li-Ion, and LiPo
- Fuel Gauges
 - Provide accurate pack and cell state-of-charge (SOC) for challenging LFP cells, particularly for the high C-rate requirements of BBUs
 - Provide accurate pack and cell SOH estimates for guaranteed performance at all times
- Active Balancers
 - Speed up cell balancing with less heat generation
 - Extend battery runtime by compensating for cell mismatch
 - Increase reliability and lifetime by maintaining continuously balanced cells

Market Trends for Datacenter Battery Backup Units

Gov. Regulation

Industry Standards

Evolving Batteries

Cost Differentiation

End-Product Differentiation

Manufacturing Localization



BMS Products for Datacenter

Battery Monitors & Protectors

	Part Number	# of Series Cells	Pack Voltage (V)	Charge/Discharge	Separate MOSFET Driver	Cell-Balancing	Coulomb Counting	Discharge Soft Start	Load/Charger Detection	OT Cell Voltage Accuracy (-20°C to +65°C)	MPS Advantages for Battery Backup Units	
N	MP2798	3 to 18	7.5 to 86	High-Side	-	✓	✓	-	-	✓	±4mV	For systems with separate current control circuitry (no integrated FET drivers); supports low-current standby mode; includes 4 dedicated NTC inputs, 3 additional I/O (config. as NTC inputs), 3.3V LDO, 5V LDO, fuse driver, watchdog timer; integrated cell-balancers support external MOSFETs
N	MP3713	3 to 10	7.5 to 86	High-Side	✓	✓	✓	✓	✓	✓	±4mV	For small packs; includes drivers for HS-FETs or GaN FETs, current-regulated discharge (soft start) to eliminate pre-charge circuit; supports low-side control, low-current standby mode; includes onboard 3.3V and 5V LDOs, fuse driver, watchdog timer; integrated cell-balancers support external MOSFETs
N	MP3714	3 to 16	7.5 to 86	High-Side	✓	✓	✓	✓	✓	✓	±4mV	Integrated drivers for HS-FETs or GaN FETs, current-regulated discharge (soft start) to eliminate pre-charge circuit; supports low-side control, low-current standby mode; includes 4 dedicated NTC inputs, 3 additional I/O (config. as NTC inputs), 3.3V LDO, 5V LDO, fuse driver, watchdog timer; integrated cell-balancers support external MOSFETs
N	MP3716	3 to 18	7.5 to 86	High-Side	✓	✓	✓	✓	✓	✓	±4mV	Integrated drivers for HS-FETs or GaN FETs, current-regulated discharge (soft start) to eliminate pre-charge circuit; supports low-side control, low-current standby mode; includes 4 dedicated NTC inputs, 3 additional I/O (config. as NTC inputs), 3.3V LDO, 5V LDO, fuse driver, watchdog timer; integrated cell-balancers support external MOSFETs
S	MP3717	4 to 20	10 to 140	High-Side	✓	✓	✓	✓	✓	✓	±4mV	Integrated drivers for HS-FETs or GaN FETs, current-regulated discharge (soft start) to eliminate pre-charge circuit; supports low-side control, low-current standby mode; includes 4 dedicated NTC inputs, 6 additional I/O (config. as NTC inputs), 3.3V LDO, 5V LDO, fuse driver, watchdog timer; integrated cell-balancers support external MOSFETs
S	MP3718	4 to 24	10 to 140	High-Side	✓	✓	✓	✓	✓	✓	±4mV	Integrated drivers for HS-FETs or GaN FETs, current-regulated discharge (soft start) to eliminate pre-charge circuit; supports low-side control, low-current standby mode; includes 4 dedicated NTC inputs, 6 additional I/O (config. as NTC inputs), 3.3V LDO, 5V LDO, fuse driver, watchdog timer; integrated cell-balancers support external MOSFETs

Battery Pack Fuel Gauges

	Part Number	# of Series Cells	Chemistry	Communication Interface	External SOC Indication	Pack SOC Indication	Cell Impedance Accuracy	Thermal Monitoring	Recommended Battery Monitor	Battery Monitor Interface	MPS Advantages for Battery Backup Units
	MPF42791	2 to 16	Li-Ion, Li-Polymer	I ² C	LED	±3%	✓	✓	MP3714	Via MCU	Provides high-accuracy cell and pack SOC estimates, SOH estimates, impedance, max available power, charge and runtime, lifetime logging
	MPF42793	2 to 16	LFP	I ² C	-	±5%	✓	✓	MP3714	Via MCU	Designed for LFP cells; provides high-accuracy cell and pack SOC estimates, SOH estimates, impedance, max available power, charge and runtime, lifetime logging
S	MPF42781	3 to 18	Li-Ion, Li-Polymer, LFP	I ² C	LED	±3% ±5% (LFP)	✓	✓	MP2798, MP3714, MP3715, MP3716	Direct	Supports all battery chemistries, including LFP; eliminates need for MCU by directly controlling MPS battery monitor; provides high-accuracy cell and pack SOC estimates, SOH estimates, impedance, max available power, charge and runtime, lifetime logging
S	MPF42786	2 to 112	Li-Ion, Li-Polymer, LFP	I ² C	LED	±3% ±5% (LFP)	✓	✓	MP2798, MP3714, MP3715, MP3716	Via MCU	Supports multiple battery monitors used for up to 112 series cells; supports all Li-ion chemistries including LFP; provides high-accuracy cell and pack SOC estimates, SOH estimates, impedance, max available power, charge and runtime, lifetime logging
S	MPF42794	2 to 24	Li-Ion, Li-Polymer, LFP	I ² C	LED	±3% ±5% (LFP)	✓	✓	MP3717, MP3718	Via MCU	Supports all battery chemistries, including LFP; provides high-accuracy cell and pack SOC estimates, SOH estimates, max available power, impedance, charge and runtime, lifetime logging

Active Balancers

	Part Number	Topology	# of Series Cells	Maximum Balance Current (A)	Minimum V _{IN} (V)	Maximum V _{IN} (V)	Shutdown Current (µA)	Efficiency @ V _{CELL} = 3.3V	Control Interface	Package	MPS Advantages for Battery Backup Units
N	MP2642	Bidirectional, Buck-Boost	2	1	3.8	16	12	0.928	2-Pin	QFN-26 (4x4)	Integrated FETs, watchdog timer, OVP, UVP, thermal shutdown; operates w/ single inductor/capacitor per IC, interleavable to support high cell-count strings; supports Li-Ion, Li-Polymer, LFP
N	MP2643	Bidirectional, Buck-Boost	2	2	3.8	16	12	0.928	2-Pin	QFN-26 (4x4)	Integrated FETs, watchdog timer, OVP, UVP, thermal shutdown; operates w/ single inductor/capacitor per IC, interleavable to support high cell-count strings; supports Li-Ion, Li-Polymer, LFP
N	MP2645	Bidirectional, Buck-Boost	2 to 5	3.75	5	24	2	0.93	1-Wire Serial	QFN-19 (4x4)	Integrated FETs, watchdog timer, thermal shutdown; operates w/ single inductor/capacitor per IC, supports 8 MPQ2645 devices for up to 33 series cells via 1 control and 1 status signal
S	MPQ2645	Bidirectional, Buck-Boost	2 to 5	3.75	5	24	2	0.93	1-Wire Serial	QFN-19 (4x4)	AEC-Q100 qualified; integrated FETs, watchdog timer, thermal shutdown; operates w/ single inductor/capacitor per IC, supports 8 MPQ2645 devices for up to 33 series cells via 1 control and 1 status signal

Why Choose MPS

For almost 30 years, Monolithic Power Systems (MPS) — headquartered in Kirkland, Washington, and listed on Nasdaq — has been powering the most important technological innovations, from electric vehicles to artificial intelligence, renewable energy systems to advanced medical devices. Our fully customized service, dedicated support, and steadfast partnerships have attracted industry leaders and startups on the cusp of groundbreaking discoveries.

MPS is agile, nimble, and forward-thinking, always looking for better, faster, and more efficient ways to drive technological progress. We forge ahead to create what's next and make a sustainable impact.

We are a global leader in powering the most important technological innovations of our lives — working with our customers to create what's next. We design high-performance, super efficient power solutions for a wide range of product categories — from AI datacenters to automation, advanced medical devices to robotics.



Expert Engineering Resources

On-Site

Embedded engineering teams join our largest customers on location

On-Demand

Knowledgeable field application engineers (FAEs) and application engineers (AEs) respond as needed to assist customers in optimizing designs

Virtual

Remote engineers provide virtual design sessions

- Product Recommendations
- Project Troubleshooting
- Technical Consulting



www.monolithicpower.com/quote-samples-support

Contact & Ordering

US Offices

MPS Kirkland ●●

5808 Lake Washington Blvd. NE
Kirkland, WA 98033, USA
Tel: +1 425-296-9956

MPS Detroit ●●

19499 Victor Parkway
Livonia, MI 48152, USA
Tel: +1 248-907-0222

MPS Florida

1555 Palm Beach Lakes Blvd.
West Palm Beach, FL 33401, USA

MPS San Jose ●●

79 Great Oaks Blvd.
San Jose, CA 95119, USA
Tel: +1 408-826-0600

MPS Phoenix ●

2065 S. Cooper Rd., Suite 3
Chandler, AZ 85826, USA

MPS North Carolina ●

Canterbury Hall
4815 Emperor Blvd.
Durham, NC 27703, USA

EU Offices

MPS Barcelona ●

Av. Josep Tarradellas 123, 5-A
08029 Barcelona, Spain
Tel: +34 93-181-5400

MPS Munich ●

Alte Landstrasse 21A
85521 Ottobrunn, Germany
Tel: +49-89-80913512-0

MPS Portugal ●

Rua D. Manuel II, 290, Piso 7
4050-344 Porto,
Portugal

MPS Netherlands ●

Haaksbergerstraat 95, 3rd Floor
7554 PA Hengelo,
The Netherlands

MPS Germany ●●●

Gutenbergstrasse 4,
77955 Ettenheim,
Germany

MPS Switzerland

Bleicheplatz 2/3, 5th Floor
8200 Schaffhausen,
Switzerland

Asia Offices

MPS China Chengdu ●●

#8 Kexin Road West Park of Export
Processing Zone West Hi-Tech Zone
Chengdu, Sichuan, 611731
Tel: +86 28-8730-3000

MPS China Hangzhou ●●

Floor 6, Building A2, Xixi Center,
No. 588 West Wenyi Road, Xihu District
Hangzhou, Zhejiang, 310012
Tel: +86 571-8981-8588

MPS China Shanghai

Floor 27, Magnolia Plaza, No. 777
Hongqiao Road, Xuhui District
Shanghai, 20030
Tel: +86 21-2225-1700

MPS China Shenzhen

Room 1401, Kingkey Riverfront Times Square
Branch North,
Binhe Avenue South, Futian District
Shenzhen Guangdong, 518054
Tel: +86 755-3688-5818-5852

MPS Taiwan Taipei ●

29F, No. 97, Section 1, Xintai 5th Road
Xizhi District, New Taipei City, Taiwan
Tel: +886 2-86911600

MPS Taiwan Hsinchu

10F, No. 8, Taiyuan 2nd Street,
Zhubei City, Hsinchu County, Taiwan 302082
Tel: +886 3-527-6600

MPS Japan Tokyo

Shinjuku Sumitomo Bldg. 31F
2-6-1 Nishishinjuku Shinjuku-ku,
Tokyo 163-0231, Japan
Tel: +81 3-5989-0885

MPS Japan Osaka

Room 301, NLC Shin-Osaka Business
Zone III, 3-14-20 Nishinakajima,
Yodogawa-ku, Osaka-shi,
Osaka 532-0011, Japan
Tel: +81 6-6300-7432

MPS Singapore

No. 8 Ubi Road 2
#08-12 Zervex, Singapore 408538

MPS Korea

I&C Building 5F, 24,
Pangyo-ro 255beon-gil,
Bundang-gu, Seongnam-si,
Gyeonggi-do, Korea 13486
Tel: +82 31-778-6819

MPS India

Unit G-12, Prestige Towers,
No 99 / 100, Residency Road,
Bangalore 560025
Tel: +91 80-4124-0312 / 20

● Regional Headquarters ● EMC Labs ● R&D Center

MPS Investor Relations

www.monolithicpower.com/investors

**Fast
Response**

Quotes, Availability, Engineering Support & Samples
www.monolithicpower.com/quote-samples-support

Order Direct
www.monolithicpower.com

Online Order Support
www.monolithicpower.com/onlineorders

