

MP279x Monitor & Protector

+

MPF4279x Fuel Gauge

=

MBM1xS-P100 Complete BMS Solution

- 7 to 16 cells in series
- Integrated high-side N-channel MOSFET driver with soft start capability
- 15-bit voltage and 16-bit current ADCs
 - 100mV current-sensing range with Coulomb counting function
- Internal and external balancing supported
- Configurable auto-recovery strategy
- 3.3V/50mA regulated MCU output
- Safety-focused design
 - Self-diagnostic
 - HW state machine
- Synchronous voltage and current measurements for cells and pack

- Supports a wide variety of lithium cells
- 2 to 16 cells in series
- Advanced battery estimation algorithm:
 - Self-learning parameters
 - Thermal modeling to predict temperature
- Cell and pack state-of-charge (SOC)
- Instantaneous available power
- Cell and pack state-of-health (SOH)
- Online cell resistance tracking with MPS Monitor & Protector
- Virtual Fuel Gauge software for quicker time to market
- Provides lifetime logging
- Low current consumption

- Turn-key system for quick time-to-market
- Up to 2.5% state-of-charge (SOC) accuracy over temperature
- 7 to 16 cells in series
- Up to 100A constant current and 150A peak current
- 10 integrated N-channel MOSFETs for heat dissipation
- 3 external temperature sensors
- CAN bus, UART, and RS-485 communication available
- External 5V regulator
- Pairs MPS Monitor & Protector with MPS Fuel Gauge to provide enhanced safety features
- Boards available now, contact MPS

Applications



E-Bikes and E-Mobility Devices



Light Electric Vehicles (EVs)



Energy Storage



UPS Applications

Complete Solution Board

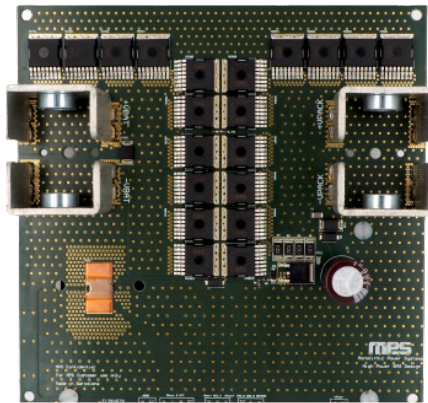
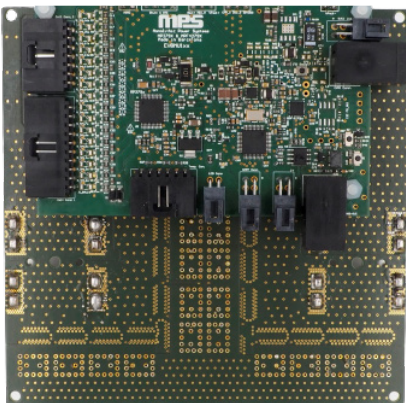

Contact

Contact MPS for more information about the **MPF4279x** and **MP279x** family, or visit our webpage: [monolithicpower.com/en/products/battery-management](https://www.monolithicpower.com/en/products/battery-management)

Solution	MPF4279x Part Number	MPF4279x Short Description	MP279x Part Number	MP279x Short Description
MBM16S-P100	MPF42790	2-Cell to 16-Cell FG with Level LEDs	MP2797	7-Cell to 16-Cell I ² C BMS
MBM14S-P100	MPF42790	2-Cell to 14-Cell FG with Level LEDs	MP2791	7-Cell to 14-Cell I ² C BMS
MBM10S-P100	MPF42795	2-Cell to 10-Cell FG with Level LEDs	MP2791	7-Cell to 14-Cell I ² C BMS
MBM16S-P100-B	MPF42791	Next-Generation 2-Cell to 16-Cell FG with Level LEDs	MP2797	7-Cell to 16-Cell I ² C BMS
MBM14S-P100-B	MPF42791	Next-Generation 2-Cell to 14-Cell FG with Level LEDs	MP2791	7-Cell to 14-Cell I ² C BMS

MPS's High-Power BMS Architecture with Advanced Fuel Gauge Technology

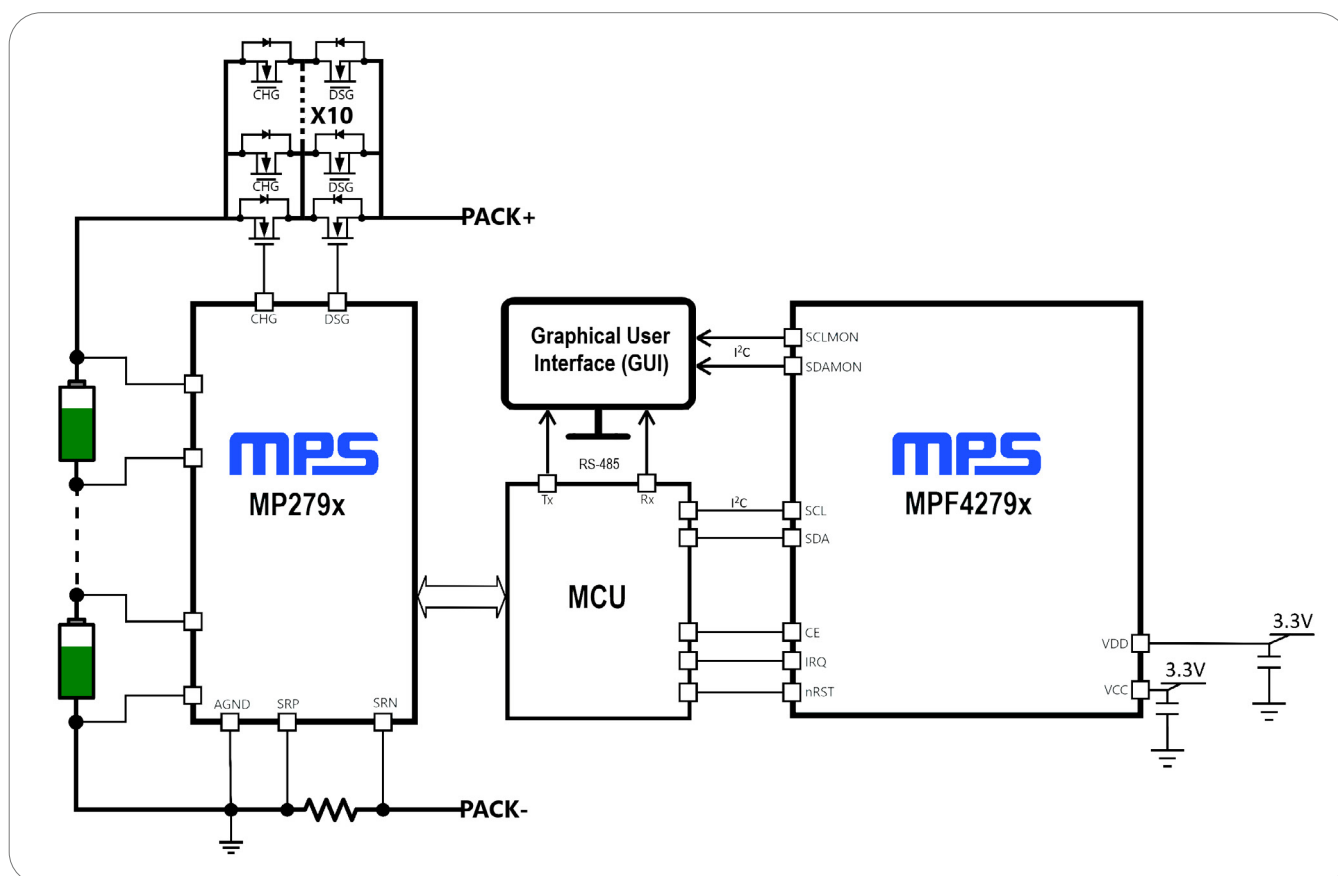

Contact

Contact MPS for more information about the MPF4279x and MP279x family, or visit our webpage: monolithicpower.com/en/products/battery-management