

Introduction

Autonomous driving is one of the most popular trends in the automotive industry. Currently, commercial-level automatic driving remains at the L2/L3 level. Automotive radar technology is gaining momentum as a solution to achieve higher levels of automated driving. With the accurate perception of millimeter-wave radar, cars can autonomously make intelligent judgements and decisions.

Millimeter-Wave Radar

At 77GHz, millimeter-wave radar features strong anti-interference capabilities, high accuracy, small size, and flexible algorithms. It can be used for various application scenarios including long-range, short-range, and 360° surround view. Millimeter-wave radars are more sensitive than ultrasonic radars, and their cost is comparable to LiDAR. As a result, millimeter-wave radar has become a growing trend in the automotive radar market.

The automotive radar market has experienced a boom in demand as autonomous driving continues to drive the industry. On-board millimeter-wave radar technology is anticipated to become a leading catalyst for this market.

Optimized Performance

A stable, reliable, and high-performance power supply solution helps support millimeter-wave radars and achieve a powerful detection performance. As a leading semiconductor manufacturer specializing in power solutions, MPS has contributed to the development of millimeter-wave radar in collaboration with Calterah, a manufacturer of CMOS process millimeter-wave radar chips.

Figure 1 shows a discrete power supply solution for the Calterah Alps series of automotive 77/79GHz millimeter-wave radars. The solution uses the [MPQ4420A-AEC1](#), [MPQ2166A-AEC1](#), and [MPQ2171-AEC1](#).

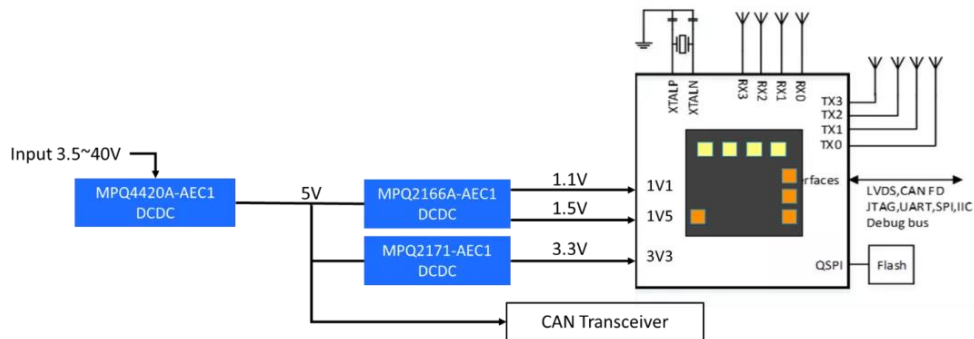

Figure 1: MPS Discrete Power Supply Solution with Calterah

We will examine the two stages of the discrete power supply solution in further detail.

First Stage

The [MPQ4420A-AEC1](#) is an AEC-Q100 certified, synchronous step-down converter with a continuous operating input voltage (V_{IN}) range between 4V and 36V. The features of the MPQ4420A-AEC1 include the following:

- Supports transient input voltages up to 36V to meet battery voltage spikes caused by other in-vehicle functions
- Supports a duty cycle up to 95% to ensure a stable output under cold-crank conditions when the battery voltage is low
- Available in a TSOT23-8 (3mmx3mm) package to save board space

- Achieves 2A of output current (I_{OUT}) with a 12V input and a 5V output conversion efficiency exceeding 95%

In addition, the MPQ4420A-AEC1 supports peak current control mode, fast loop response, excellent dynamic performance, and load regulation as low as $\pm 0.2\%$ to ensure the reliability of the back-up circuit and power supply. Robust protections include input under-voltage protection (UVP), output over-current protection (OCP), and over-temperature protection (OTP), which add another level of security to the entire millimeter-wave radar system.

Figure 2 shows the typical application circuit of the MPQ4420A-AEC1.

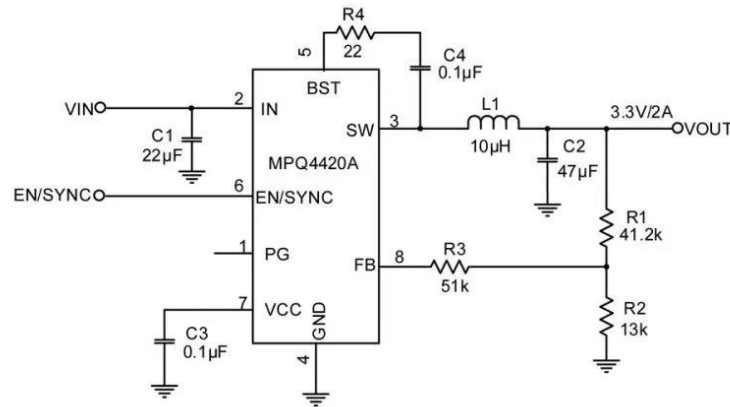

Figure 2: MPQ4420A-AEC1 Typical Application

Second Stage

Similar to the MPQ4420A-AEC1, the [MPQ2166A-AEC1](#) and [MPQ2171-AEC1](#) are also AEC-Q100 certified, automotive-grade, synchronous step-down converters.

The MPQ2166A-AEC1 is a single-input, dual-output, synchronous converter. The device can operate with two output voltages that are 180° out of phase, which reduces the input voltage ripple and the number of required input capacitors.

Based on the actual requirements, the two output currents can be flexibly configured as 2A/2A or 3A/1A. The operating frequency is set by external resistors, and the maximum switching frequency (f_{sw}) is 3MHz. The ultra-high f_{sw} can use a physically smaller power inductor to reduce the overall layout area.

Under light loads, the MPQ2166A-AEC1 supports advanced asynchronous modulation (AAM) mode and forced continuous conduction mode (FCCM), with a peak conversion efficiency exceeding 90%.

The automotive platform has stringent requirements for a power chip's conversion efficiency and static power consumption. To address these requirements, the MPQ2166A-AEC1 supports a 65µA quiescent current, and its ultra-low static power consumption makes it ideal for automotive environments.

Additional features include the following:

- Supports a 2.7V to 6V V_{IN} range, 100% duty cycle operation, and can supply power for both 1V1 and 1V5 millimeter-wave radar channels at the same time
- Adopts peak current control and excellent dynamic performance, which contribute to the stable operation of millimeter-wave radar
- Provides robust protections including OCP, OTP, and SCP to improve system reliability
- Available in a QFN-18 (2.5mmx3.5mm) package

Figure 3 shows the typical application circuit of the MPQ2166A-AEC1.

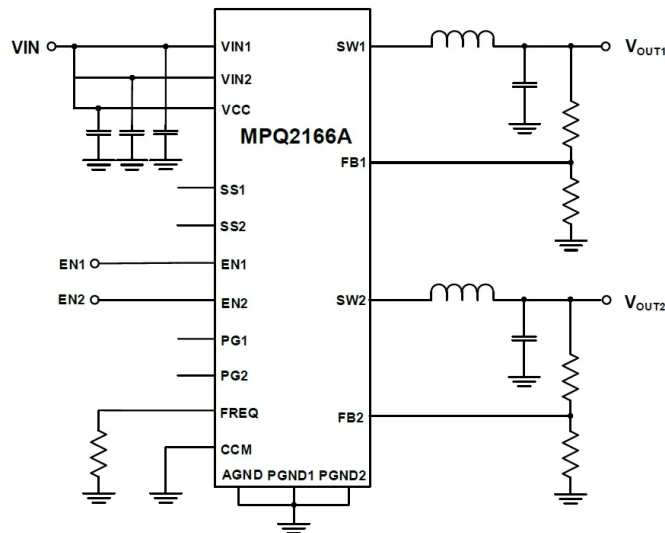

Figure 3: MPQ2166A-AEC1 Typical Application

The MPQ2171-AEC1 is a step-down, switch-mode converter with integrated power MOSFETs in a TSOT23-8 (3mmx3mm) package. This device provides the following features:

- Supports a 2.5V to 5.5V V_{IN} range and 100% duty cycle operation that supplies power for the 3V3 millimeter-wave radar channel
- Supports up to 1A of I_{OUT} , a default 2.6MHz f_{SW} , and peak conversion efficiency exceeding 90%
- Adopts constant-on-time (COT) control to achieve fast loop response and excellent, dynamic performance
- Offers protections such as OCP, OTP, and SCP

Figure 4 shows the typical application circuit of the MPQ2171-AEC1.

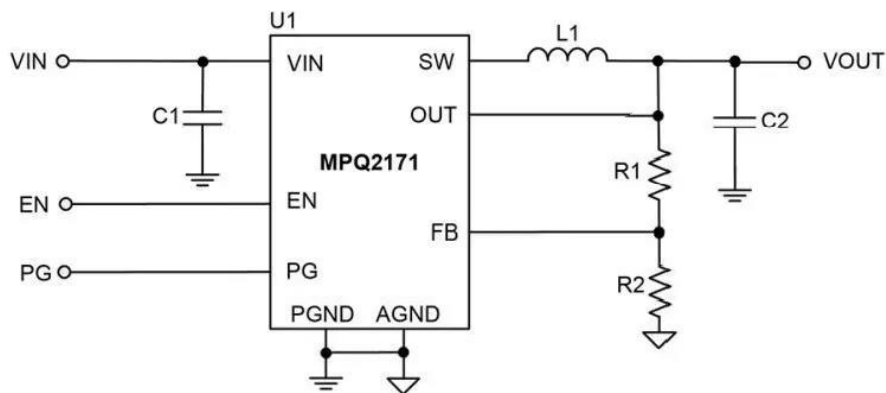

Figure 4: MPQ2171-AEC1 Typical Application

Conclusion

Among automotive radar technology, millimeter-wave radar achieves powerful detection performance for the advancement of autonomous driving. In this article, we reviewed a discrete power supply solution using the Calterah Alps series and the [MPQ4420A-AEC1](#), [MPQ2166A-AEC1](#), and [MPQ2171-AEC1](#). MPS is a forward-thinking power supply manufacturer that continues to create innovative solutions for a wide array of applications.