

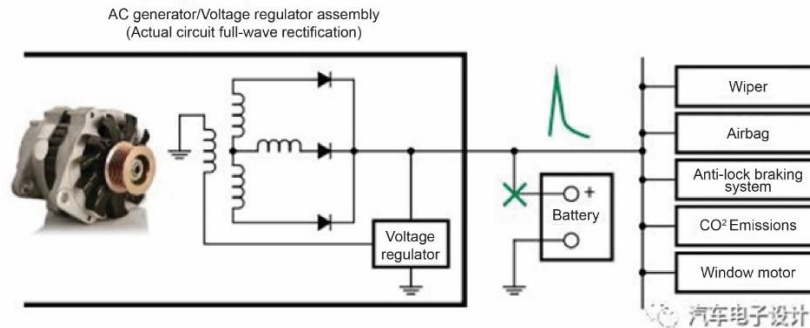

Teardown of USB Charging Module in Mercedes Benz E-Class Cars—How the MPQ448x Family Simplifies Design

Written by Zhu Yulong, Translated by Zhenzhen Jia, Technical Editor, and Edited by Ariel Potter, Marketing/Technical Writer at MPS

I first saw a 12-USB charging port design at in the new E-Class line of cars from Mercedes Benz in China. Twelve USB ports in the inside of a car? This to me was an incredible feat I didn't even know was possible. It was so surprising to see, knowing that designing even a single USB charging port in a car is very specific and difficult considering protection and voltage conversion functions. So how do you design *twelve* of them?



Most of the transient in a vehicle's electrical system are caused by AC generators

USB ports in general must be designed very carefully. In this case, placing all of those ports around the car was bound to get tricky. The locations of certain ports can make the module shape irregular, and having so many ports would increase the complexity of the overall design. USB ports also include many functions, such as conversion to low voltage, handshake recognition of various mobile phones, and mobile phone protection, which are all very important to work into the design as well. If these functions are not considered, the USB voltage may cause voltage output instability and exceed the mobile device battery's limit.

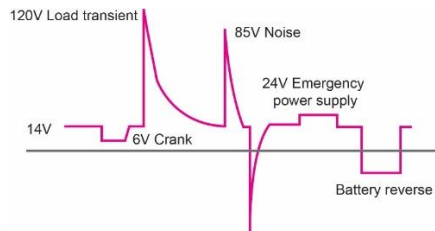

International Standard ISO 7637

- Applicable to road vehicles - electrical interference by conducting and coupling.
- Automotive Electromagnetic Compatibility (EMC) transient requirements.
 - Pulse 1 Inductive load interruption- disconnects the power supply of inductive load when test equipment (DUT) is connected with inductive load in parallel.
 - Pulse 2 Series inductance load interruption- interrupts current and causes load transient.
 - Pulse 3 Switching peak
 - 3a Negative transients surge
 - 3b Positive transient surge
 - Pulse 4 Starter crank - the battery voltage drops during the start-up of the motor which often occurs in cold weather.
 - Pulse 5 Load transient - the battery is disconnected when it's charged by AC generator.
 - Pulse 6 Ignition coil interruption
 - Pulse 7 Magnetic field attenuation of AC generator
 - Pulse 1,2,3a,3b,5,6,7 The high voltage transients input to the power supply: pulse 4 defines the minimum battery voltage

The voltage range of the car battery swings from 8 to 16V, the current is very large, and the load may be broken open at any time. The 12V power bus produces a surge voltage more than several times the power supply voltage. A large operation, such as a battery misconnection or a double voltage jumpstart (24V), can cause the USB charger’s supply voltage to exceed the limit value.

In most designs, DC/DC converters sit directly off the car battery and must contend with transient suppression issues. The over-voltage protection (OVP) function of the converter can solve the over-voltage problem, but does not handle surge protection. In turn, a TVS diode can perform surge protection but not OVP for an extended amount of time. The ideal situation would be to combine an OVP device and a TVS diode, but the cost and package would be much higher than each on their own.

So how was Mercedes Benz able to accommodate so many USB ports in their design? To find out, I had to get my hands on one of their USB charging modules. This particular module is used in the new E-class models, which exudes cutting-edge technology as reflected in their 12.3-inch all-in-one LCD instrument panel, large central control screen, and multi-beam headlights that contain 84 LEDs.



In addition to these advanced features, the cockpit contains a high level of consumer power. The new E-class front row provides a wireless charging surface supporting the Qi standard, while the back row is equipped with a special USB charging box. As far as I know, only E300L or above models were equipped with these features.

So let’s take this module apart and see how it works.

Exterior



Inside an ABS plastic shell, the module is equipped with an internal plug-in button for easy installation. Additionally, there's a seldom-seen USB Type-C charging port in the module alongside a much more common Type-A port.



The input interface on the back of the module has three input ports.



The entire module is wedge-shaped and thin for ease of insertion. This answers the question of putting ports in tricky places in the car. Quite a bit of thought went into this design.



Looking at the specification shows fairly straightforward configuration.

- Operating input voltage range: 9 ~ 16V
- Output voltage: 4.75 ~ 5.25V
- Maximum current: 3A

Interior

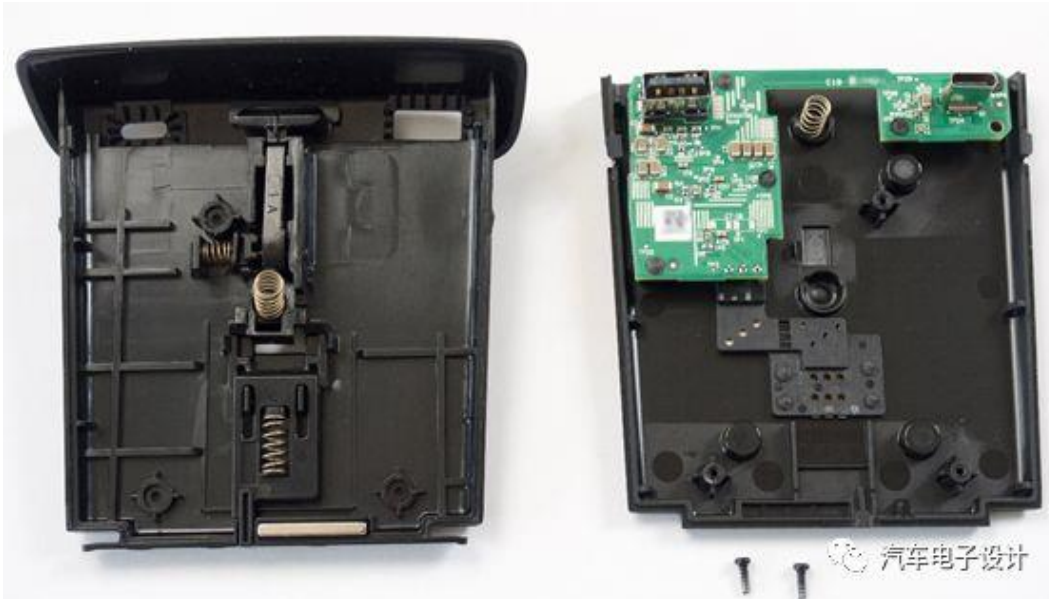

Removing the two screws on the back exposes the internal structure of the module. The structure itself is not complicated, and the PCB only accounts for a third of the area. The design is incredibly small, and there are virtually no external components needed – this answers the questions of how the module can be so small. Due to limitations with the mechanical structure and design thickness, it looks like Mercedes Benz had to choose a highly integrated solution.

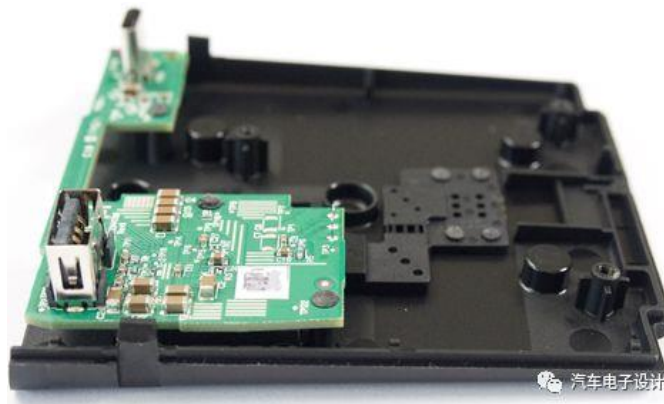

The PCB uses a 4-layer design with exposed copper for heat dissipation.

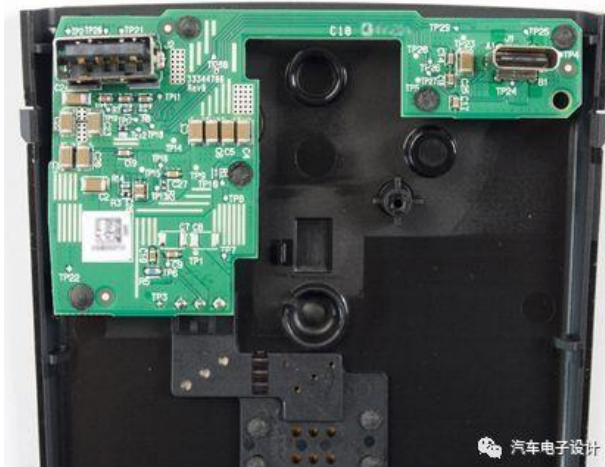

The PCB is fixed by five plastic points, which I was able to cut through easily.

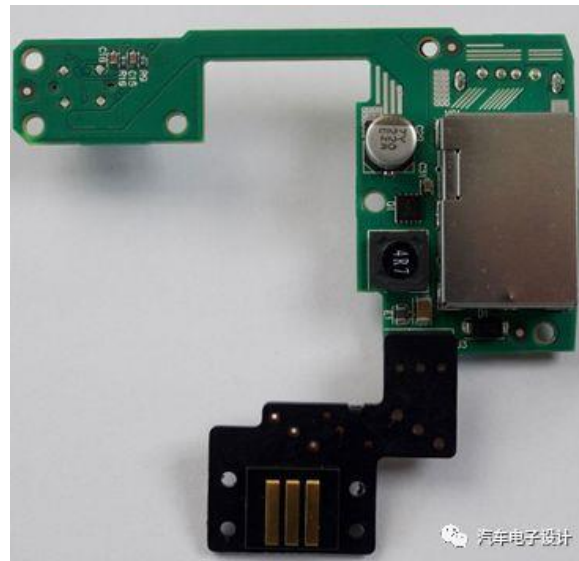

There are not too many components in the bottom layer, just an input filter and reverse-polarity protection circuit. The important circuit is shielded by a metal cover, which is extremely important for EMI compliance. Considering that strict EMC compatibility is required to meet Mercedes Benz’s requirements, this shield is a great help for protecting outside components from emissions.

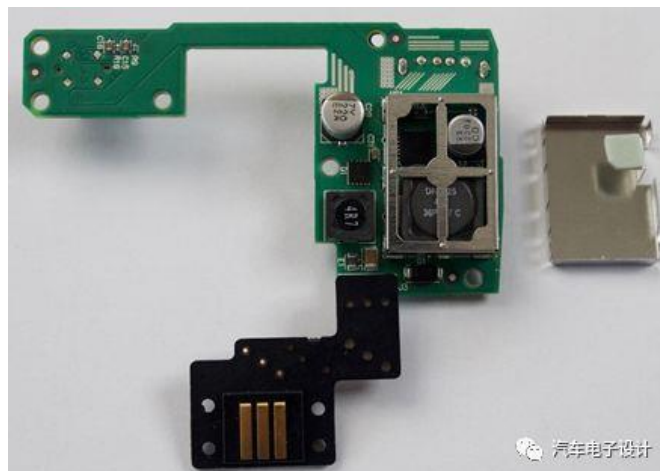

Removing the metal cover shows the inductor, capacitor, and main chip.

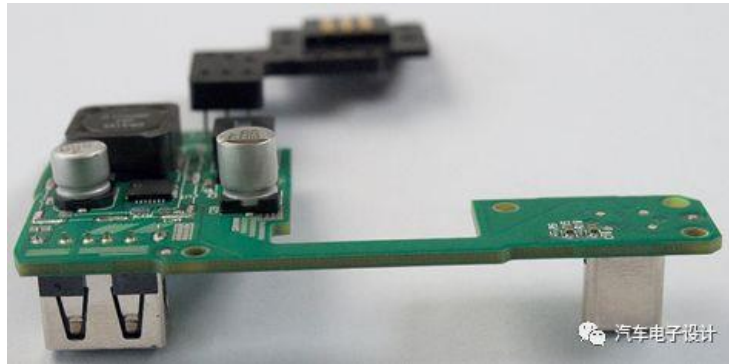

The main chip and inductor circuit are very simple.



The main chip is an automotive-grade solution from the MPQ448x family from MPS, which is a natural solution for Mercedes Benz’s design challenges.

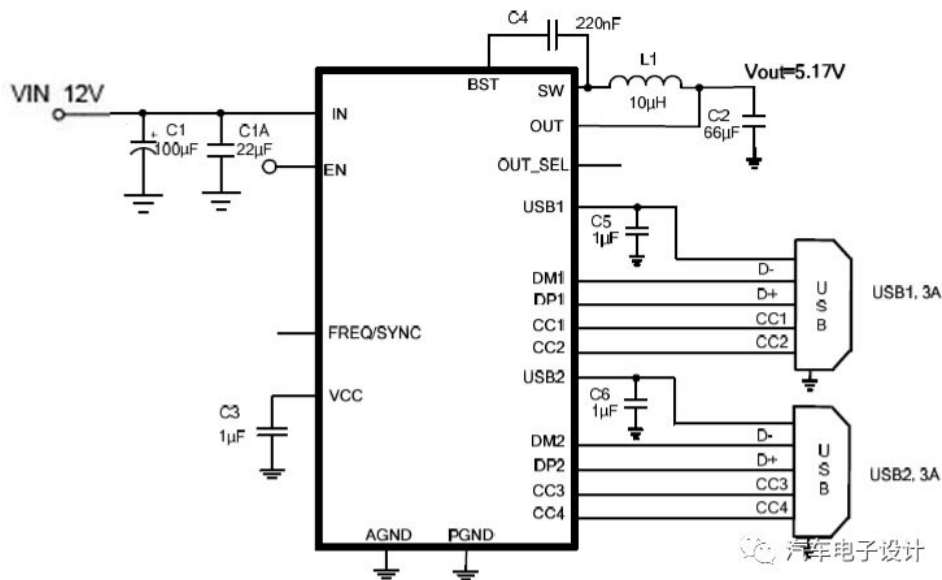

The MPQ448x-AEC1 line of converters are compact solutions that achieve 6A of continuous output current and can support Type-C 3A and Type-A 2.4A. The MPQ448x-AEC1 integrates a 40V DC/DC step-down converter with two internal power MOSFETs, USB handshake recognition, and a current-limit circuit. For a 6A DC/DC step-down circuit, the low 18mΩ/15mΩ power MOSFET resistance really helps to ensure high power conversion efficiency, which in turn reduces the thermal heating of the module.

Testing



The charging test for the Type-A port showed that the device supports various protocols, such as Apple 2.4A, Samsung 2A, and DCP 1.5A.



The actual test on an iPhone 7 Plus with 20% battery power showed a 5.1V output, 1.97A current, and power up to 10W.

The Type-C port showed a 4.76V voltage, 3A current, and power up to 14.3W. The measured value matches the 3A output capability.



When testing the Type-C and Type-A ports simultaneously, I got an output of 3A and 2.4A respectively. The output capacity is very large.



The power density of the chip is so high, that it can offer 26.6W of total power on its own (14.3W Type-C plus 12.3W Type-A). Impressive!

Summary

In my opinion, engineers of luxury cars such as BMW, Mercedes Benz and Audi are very strict about their designs and are willing to adopt more advanced solutions. As the saying goes, you get what you pay for, and in the case of the MPQ448x, you get a lot of bang for your buck.

In these cars, money is usually spent in places you can't see. The disassembled car USB charging module showed high integration and elegant minimalism, but also showed the adoption of a sophisticated dual output design with mainstream Type-A and forward-thinking Type-C ports. The MPQ448x is a one-and-done device that can accommodate Mercedes Benz's high number of charging ports using the simplest solution possible. Some domestic cars in China are also equipped with many USB charging ports, but the modules are often designed in a far less integrated fashion. They too could benefit from an MPS solution!

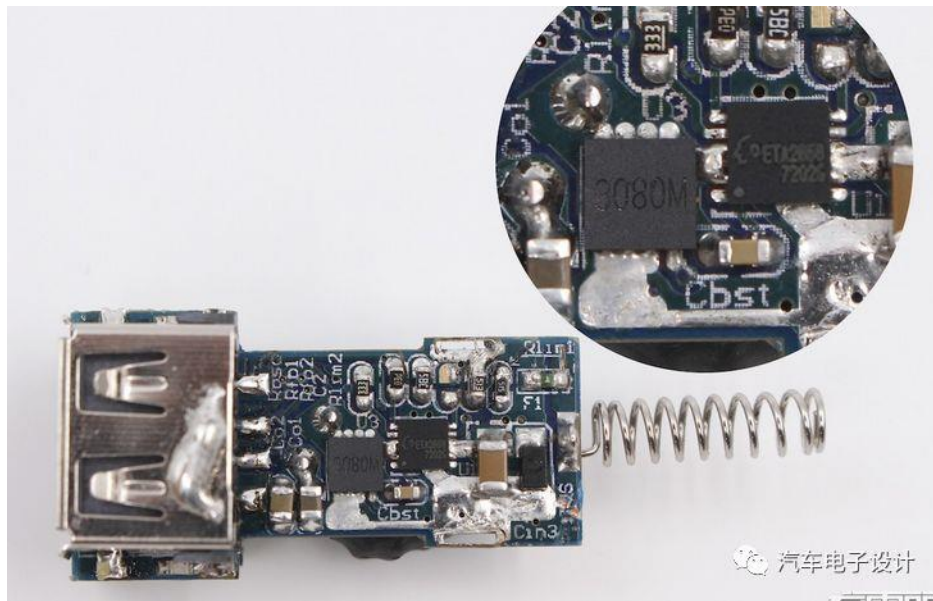

To learn more about MPS USB charging products, visit our [Automotive USB Charging Port page](#). Or our [automotive solutions](#) page